

1

This is me!



◆ Scope of unit 1

Vocabulary

- ◆ mommy, daddy, brother, sister.
- ◆ eye, ear, mouth, nose, hair, arm, leg, foot, hand.
- ◆ one, two.
- ◆ red, yellow, blue, green, orange, brown.

Language

- ◆ This is my (mommy).
- ◆ I have 2 (ear)s.
- ◆ It's (yellow).
- ◆ I like

Phonics

- ◆ / h / : Hello, hair, hand.
- ◆ / b / : bye, blue, busy bee, brown.

Values

- ◆ Tolerance and acceptance of others.

Integrated cross-curriculum topics

- ◆ Science : The senses, Body parts.
- ◆ Art : Colors, A monster family.

Lesson 1

Vocabulary & Language Use

Objectives SB P. (2 – 4) / AB P. (2 – 4)

- ♦ To identify vocabulary for family members. - للتعرف على أفراد العائلة.
- ♦ To introduce the family members. - لتقديم أفراد العائلة.
- ♦ To ask and answer question **"Who is this?"** - للسؤال والجواب ب

Family



This is my family



Daddy

أبي



Mommy

أمي



brother

أخ















sister

أخت

Unit 1

Language Use

- 1
- ◆ Who is this? - للسؤال عن شخص (من هذا؟)
 - ◆ This is my - عند تقديم شخص للآخرين (هذا يكون

	Who is this?		This is my Mommy.	
	Who is this?		This is my Daddy.	
	Who is this?		This is my brother.	
	Who is this?		This is my sister.	

- 2
- ◆ I'm - تستخدم عند تقديم أنفسنا.

	I'm Adel.		I'm Dina.
---	-----------	---	-----------

تابع جديد زاكروولي على موقعنا
<https://www.zakrooly.com>

Activities

1 Match.

صل.

1) family •



2) daddy •



3) mommy •

4) brother •



5) sister •

2 Look and circle.

أنظر و ضع دائرة حول الإجابة الصحيحة.

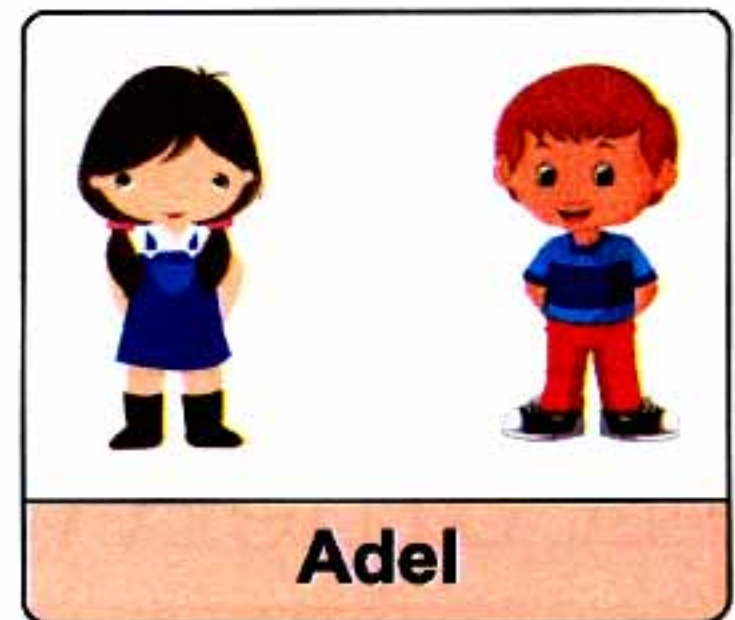
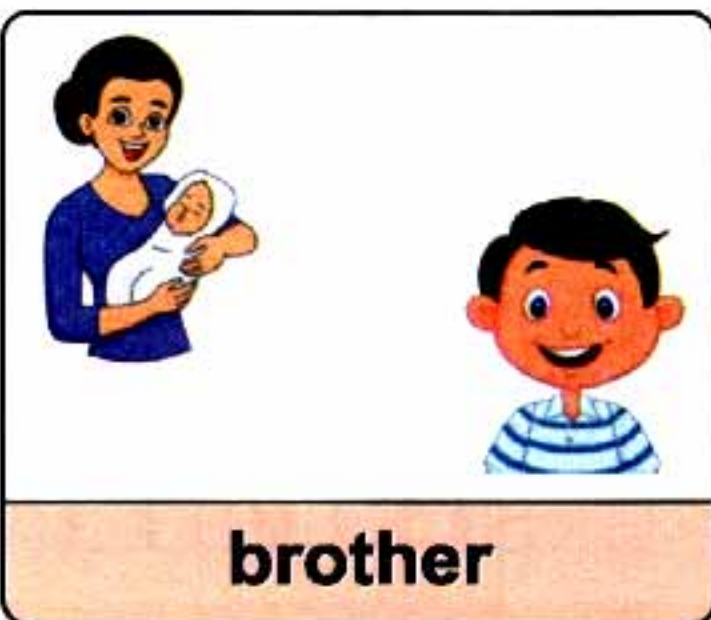
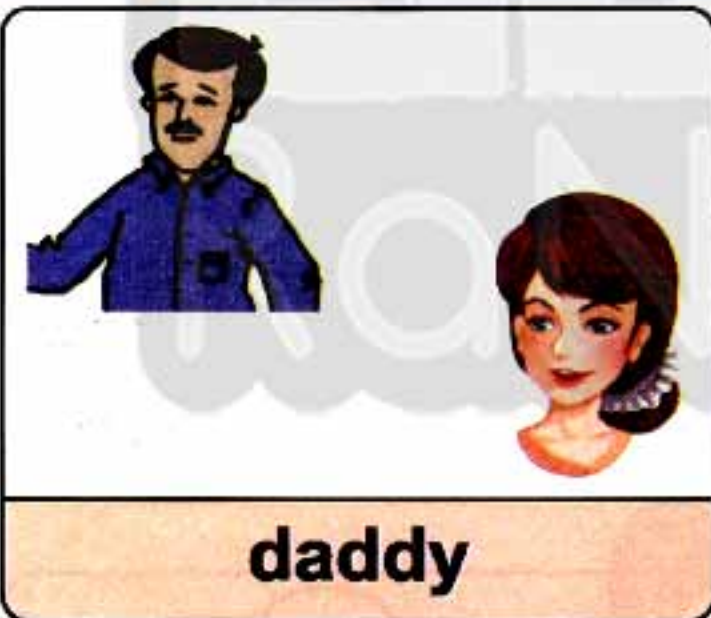

Unit 1

3 Look and tick (✓).

أنظرو وضع علامة (✓).

1) This is my family.



Yes

No

2) This is my mommy.



3) This is my brother.



4) This is my daddy.

5) This is my sister.

4 Trace and color.

تتبع النقط و لون.



family

daddy

mommy

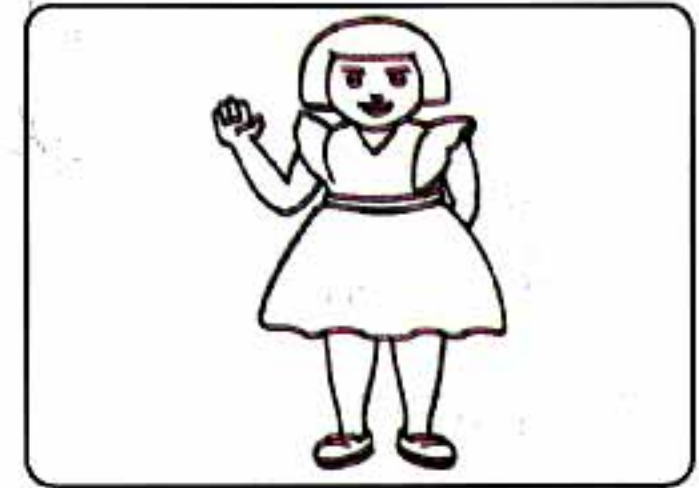

brother

sister

5 Look and tick (✓) the right answer. أنظرو وضع علامة (✓).

Who is this?



- This is my daddy.
 This is my brother.

Who is this?



- This is my mommy.
 This is my sister.

Who is this?



- This is my daddy.
 This is my mommy.

Who is this?



- This is my brother.
 This is my sister.

6 Color and say.

لون و قل.



Lesson 2

What is this?

Objectives SB P. (5) / AB P. (5)

- ◆ To identify vocabulary for parts of the face. - للتعرف على أجزاء الوجه.
- ◆ To use vocabulary for parts of the face. - لاستخدام الكلمات الخاصة بأجزاء الوجه.
- ◆ To ask and answer question "What is this?" - للسؤال والجواب ب

Parts of the face



Language Use

1 ♦ What is this?

♦ This is my

- تستخدم للسؤال عن الأشياء (ما هذا؟)

- تستخدم للتعريف بأحد أعضاء الجسم.

What is this?



This is my face.



What is this?



This is my hair.



What is this?



This is my nose.



What is this?



This is my ear.



What is this?



This is my eye.



What is this?



This is my mouth.



Unit 1

Activities

1 Match.

صل.

1) hair •



2) nose •



3) mouth •

4) ear •



5) eye •

2 Look and circle.

أنظر و ضع دائرة حول الإجابة الصحيحة.

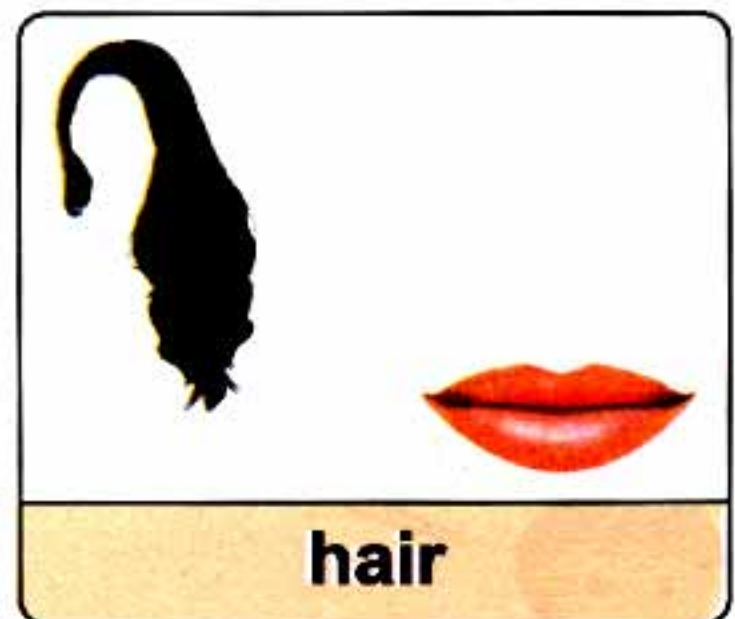
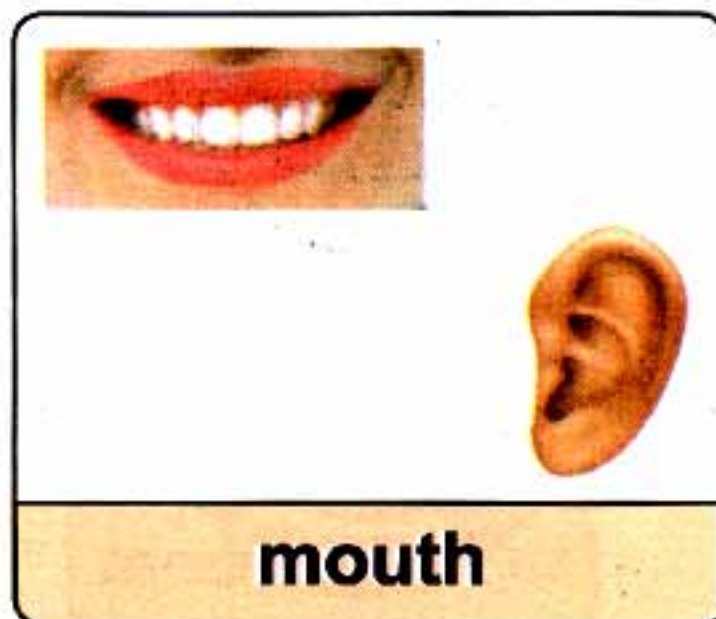
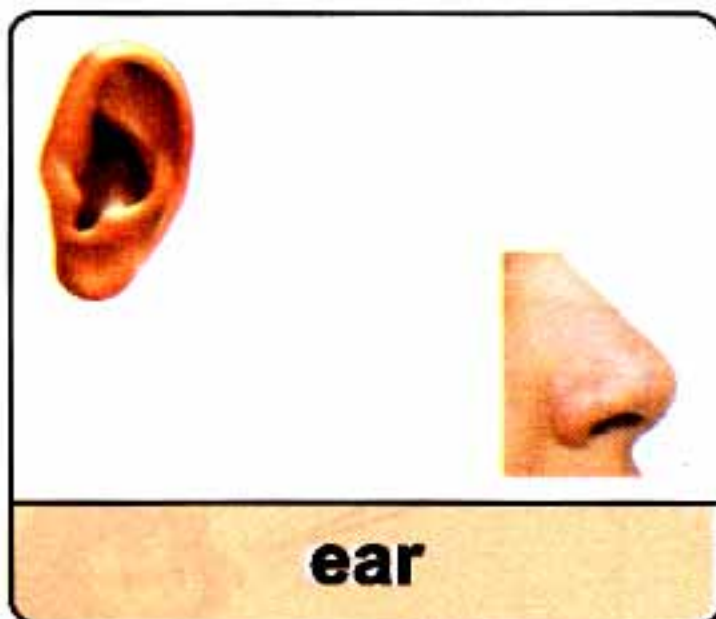
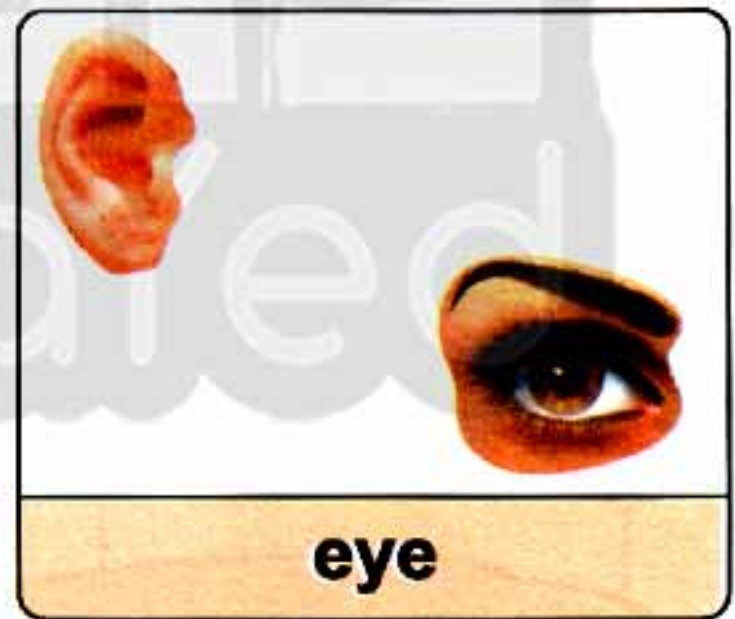
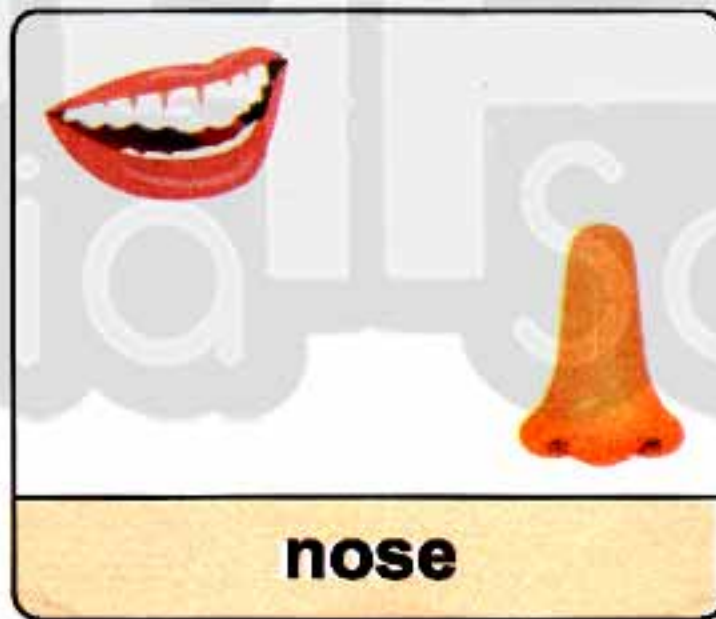

3 Look and tick (✓).

أنظر و ضع علامة (✓).

1) This is my nose.

2) This is my ear.

3) This is my mouth.

4) This is my eye.

5) This is my hair.

6) This is my face.



Yes

No

4 Trace and color.

تتبع النقط و لون.

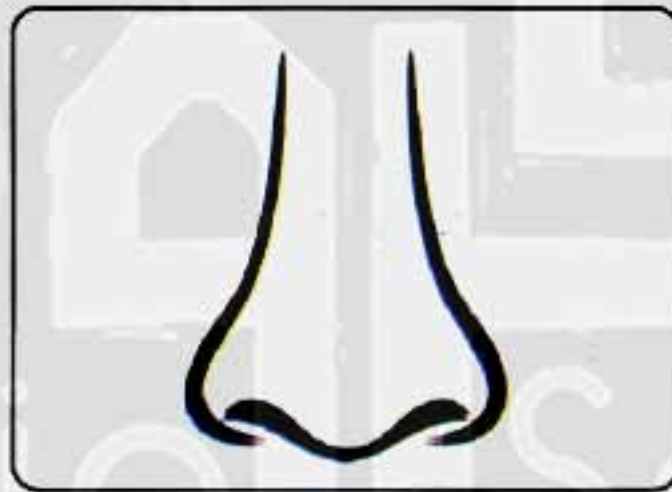

face

nose

ear

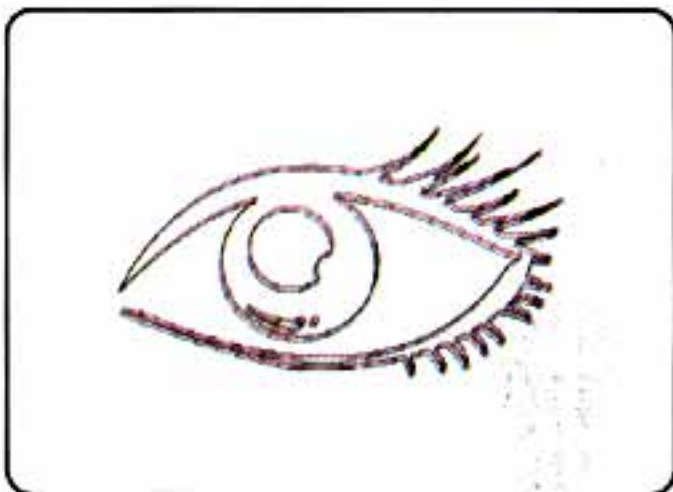

eye

mouth

hair

Unit 1

5 Look and tick (✓) the right answer. أنظرو وضع علامة (✓).

What is this?



- This is my nose.
 This is my ear.

What is this?



- This is my face.
 This is my hair.

What is this?



- This is my mouth.
 This is my eye.

What is this?



- This is my nose.
 This is my hair.

What is this?



- This is my eye.
 This is my ear.

6 Point and say.

أشير إلى و قل.



This is my



This is my

1 or 2 (connect with Math)

Lesson 3

Objectives SB P. (6 - 7) / AB P. (6 - 7)

- ◆ To identify vocabulary for parts of the body. - للتعرف على أجزاء الجسد
- ◆ To use vocabulary for parts of the face. - لاستخدام الكلمات الخاصة بأجزاء الوجه.
- ◆ To use numbers 1 or 2 with parts of the body. - لاستخدام رقم 1 أو 2 مع أجزاء الجسد.

Parts of the body

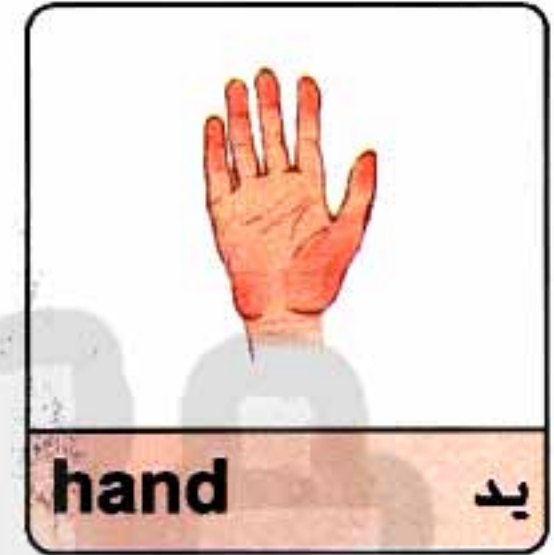

تابع جديد زاكروولي على موقعنا
<https://www.zakrooly.com>

Notes

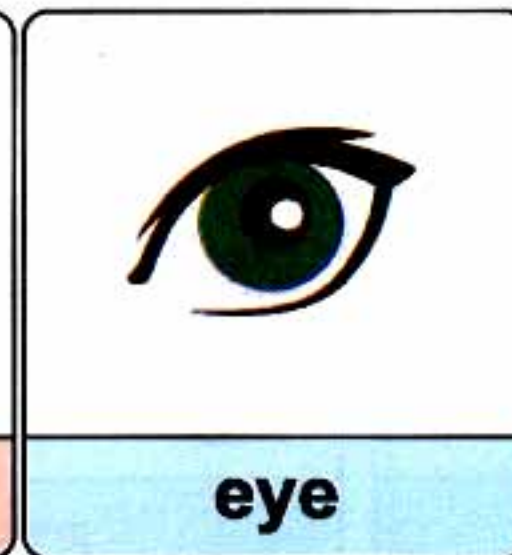
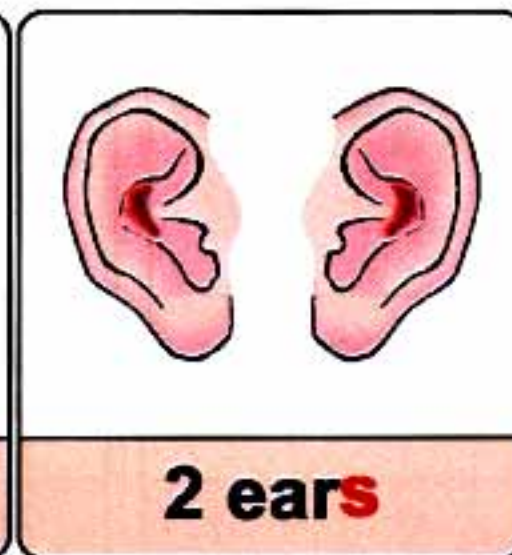
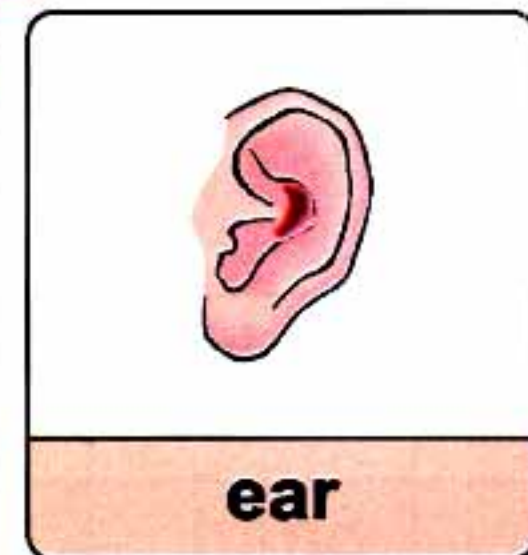

Unit 1



arm



2 arms

Language Use

1 ♦ I have 1

- تستخدم عند الحديث عن جزء من الجسم
وهبنا الله منه واحد فقط

I have 1 face.



I have 1 nose.



I have 1 mouth.

2 ♦ I have 2

- تستخدم عند الحديث عن جزء من الجسم
وهبنا الله منه اثنان

I have 2 ears.



I have 2 eyes.



I have 2 hands.

Activities

1 Match.

1) 1 mouth •



صل.



2) 2 eyes •



3) leg •

4) foot •



5) hand •



6) 2 arms •

2 Look and circle.

أنظرو وضع دائرة حول الإجابة الصحيحة.



hand



2 ears

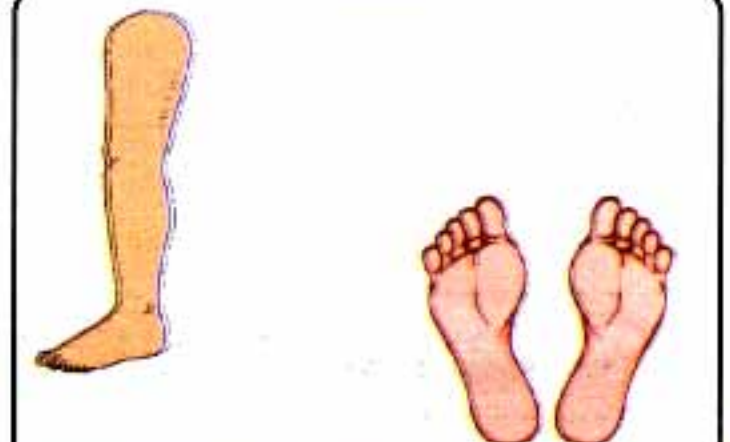

leg

Unit 1

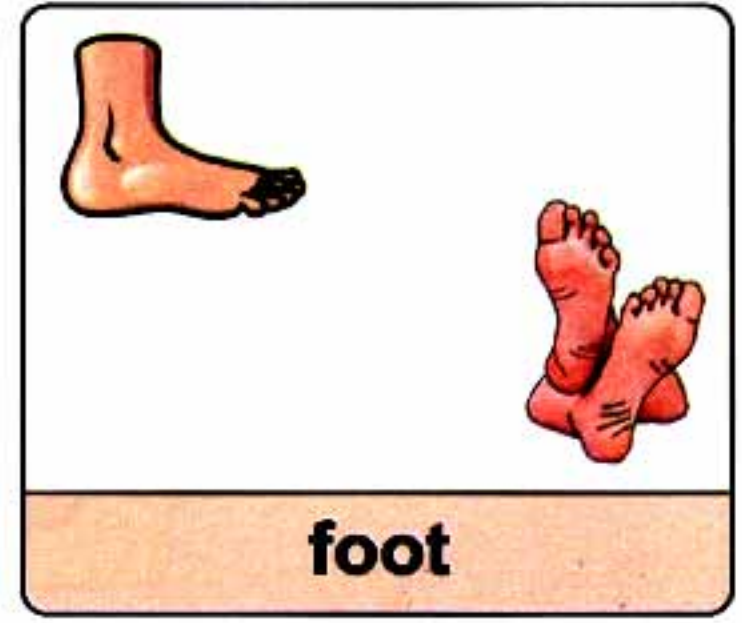
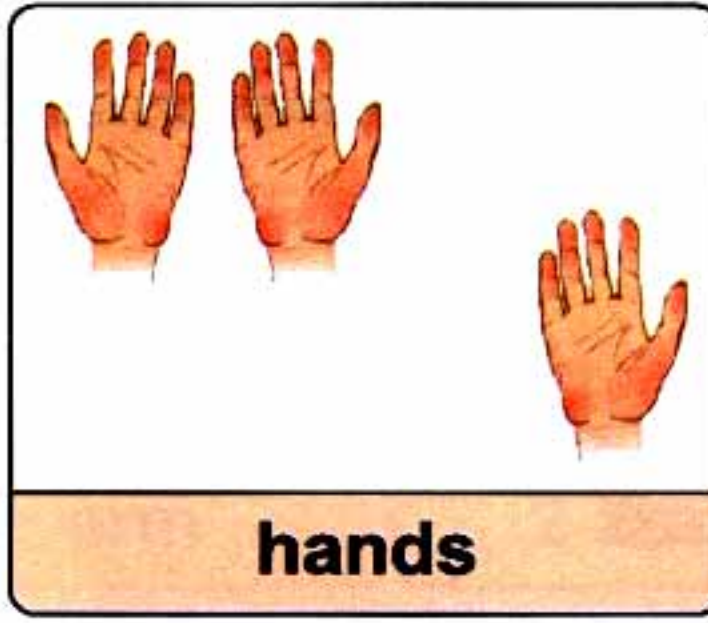
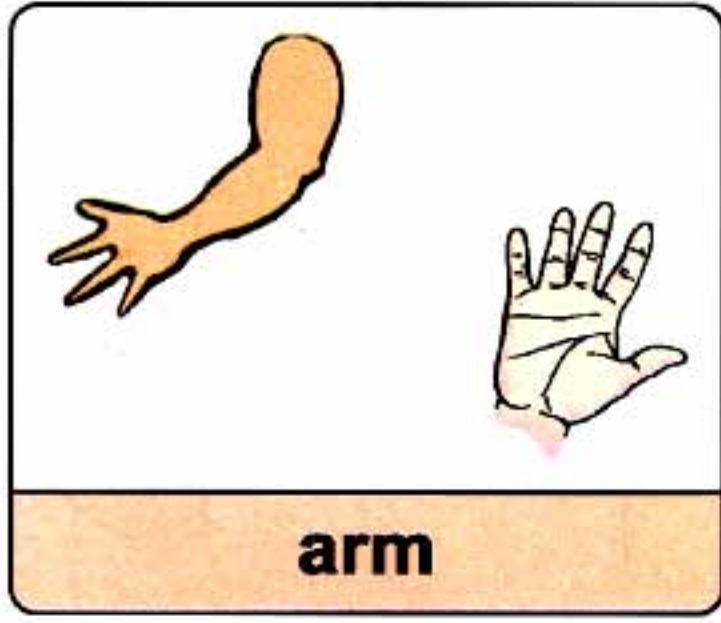

3 Write 1 or 2.

اكتب 1 أو 2.

1) I have eyes.2) I have mouth.3) I have face.4) I have ears.5) I have hands.6) I have nose.

تابع جديد زاكروولي على
فيسبوك
تويتر
وانس اب
تليجرام

4 Trace.

تتبع.





5 Look and match.

أنظر و صل.



تابعنا على صفحتنا على الفيسبوك
www.facebook.com/ZakrolySite

Lesson 4

Life skills

Objectives SB P. (8) / AB P. (8)

- ♦ To identify vocabulary for colors. - للتعرف على الألوان.
- ♦ To use vocabulary for colors and eyes. - لاستخدام الكلمات الخاصة بالألوان ولون العيون.
- ♦ To acquire the value of acceptance of others. - تقبل الآخرين واختلافاتهم.

Colors



brown

لون بني



green

لون أخضر



black

لون أسود



blue

لون أزرق



brown eyes

عيون بني



green eyes

عيون خضراء



black eyes

عيون سوداء



blue eyes

عيون زرقاء



تابعنا على صفحتنا على الفيسبوك
www.facebook.com/ZakroolySite

Language Use

1 ♦ I have eyes. - عندما نتحدث عن لون العين.



I have **green** eyes.
أنا لدى عيون خضراء.

I have **blue** eyes.
أنا لدى عيون زرقاء.

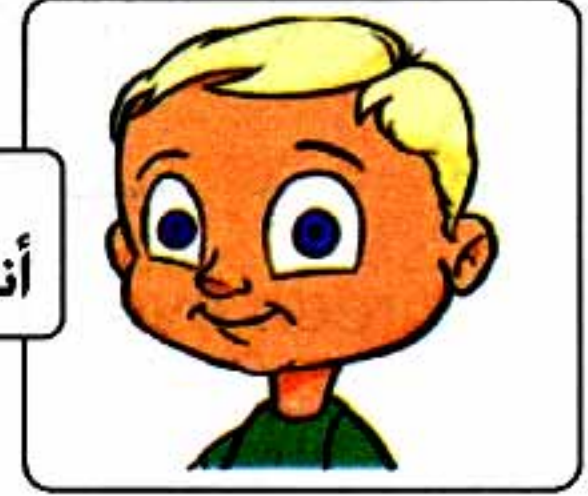

I have **brown** eyes.
أنا لدى عيون بنى.

I have **black** eyes.
أنا لدى عيون سوداء.



2 ♦ We are all beautiful. - عندما نتحدث بأن الله أنعم علينا جميعاً بحسن الخلق.



Unit 1

Activities

1 Match.

- 1) brown eyes •
- 2) black eyes •
- 3) green eyes •
- 4) blue eyes •

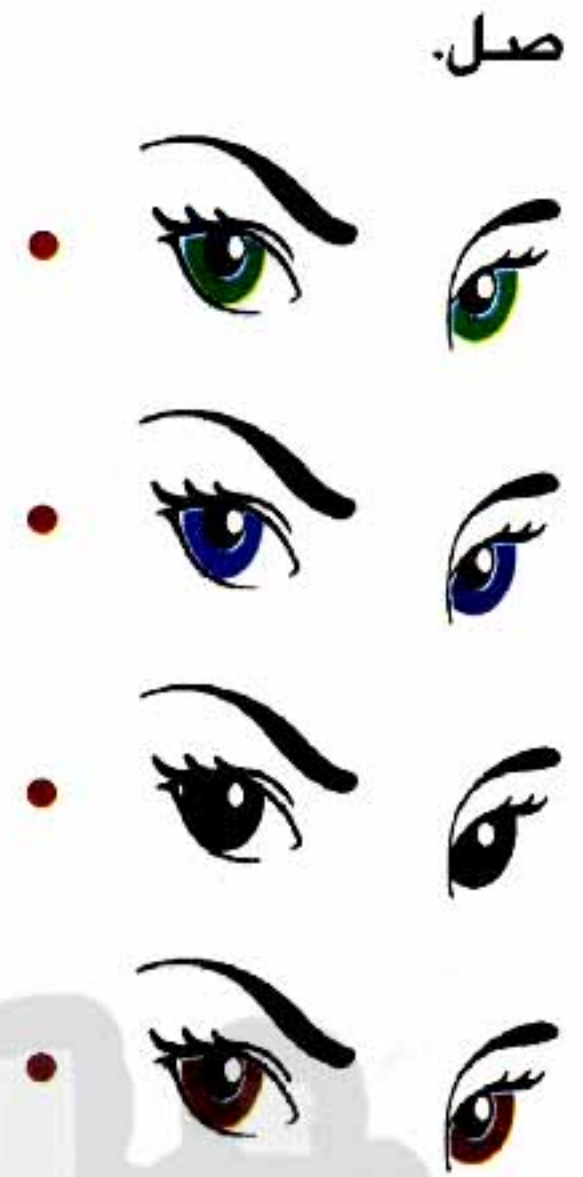

2 Look and circle.

أنظرو وضع دائرة حول الإجابة الصحيحة.



I have (green – black) eyes.



I have (blue – brown) eyes.



I have (black – brown) eyes.



I have (blue – green) eyes.

3 Look and tick (✓).

أنظرو وضع علامة (✓).

1) I have black eyes.



Yes

No

2) I have green eyes.



3) I have brown eyes.



4) I have blue eyes.



5) We are all beautiful.



4 Trace and color.

تتبع النقط و لون.



green eyes



blue eyes



brown eyes



black eyes

Lesson 5

My senses
(connect with science)

Objectives SB P. (9) / AB P. (9)

- ◆ To learn about the five senses. - لتعلم الحواس الخمسة.
- ◆ To reinforce vocabulary about parts of the body. - لتأكيد المعاني الخاصة بأجزاء الجسم.
- ◆ To use verbs of senses. - لاستخدام الأفعال الخاصة بالحواس.

The five senses

Parts of the body

Verbs used

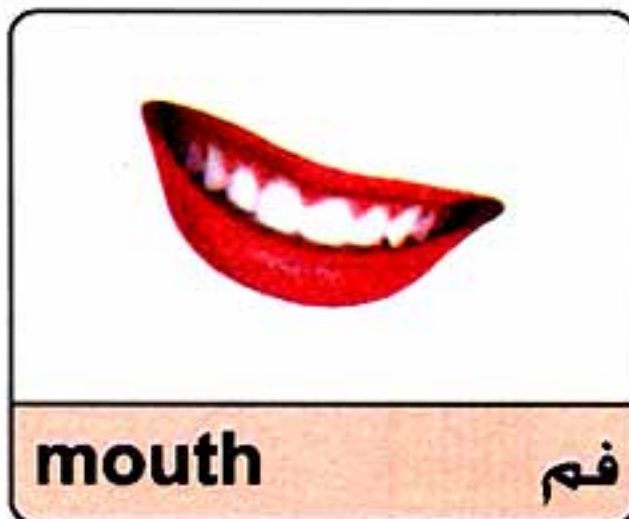
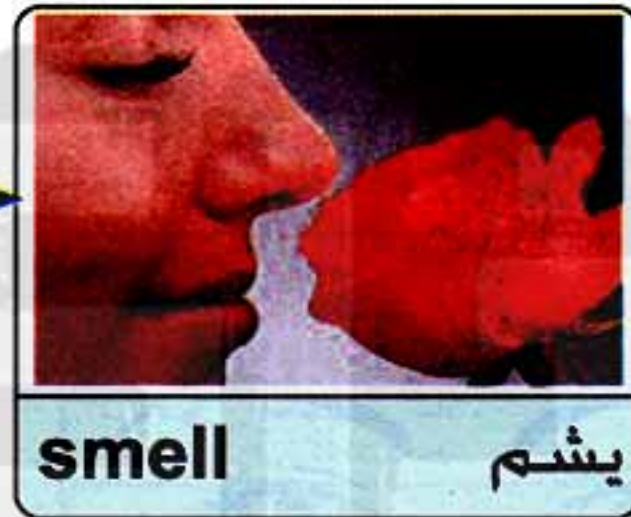
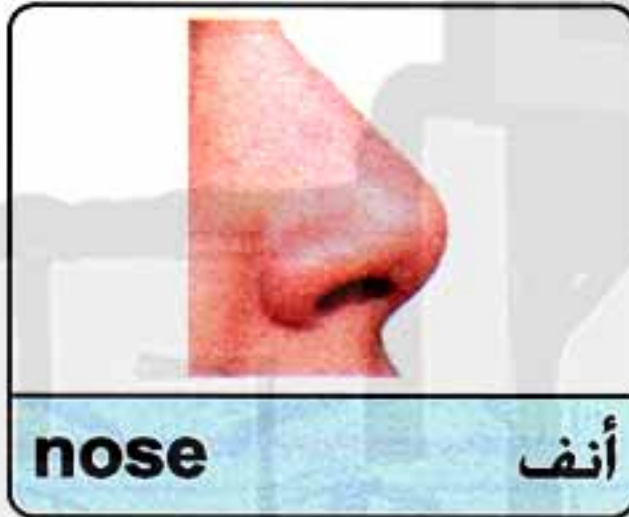

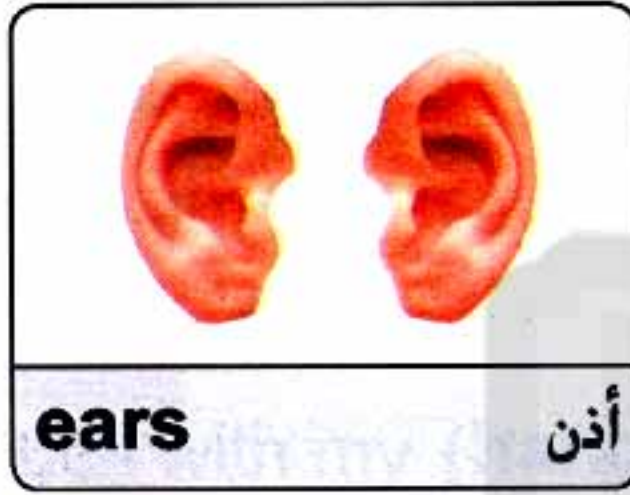
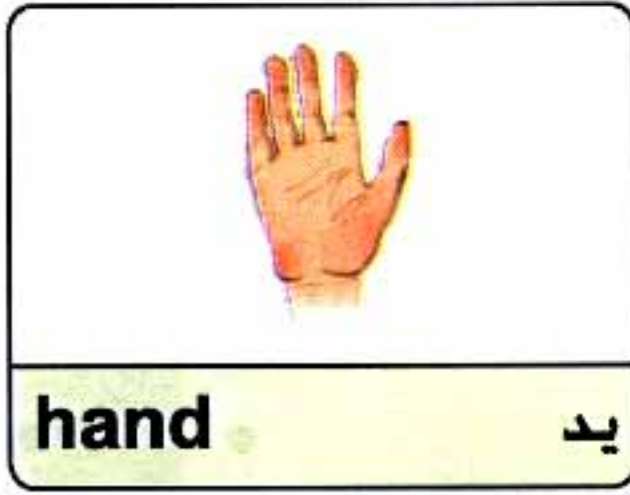

Language Use



I **smell** with my nose.
أنا أشم بأنفسي.

I **taste** with my mouth.
أنا أتذوق بفمي.



I **see** with my eyes.
أنا أرى بعيني.

I **touch** with my hands.
أنا ألمس بيدي.



I **hear** with my ears.
أنا أسمع بأذني.

Unit 1

Activities

1 Match.

صل.

1) smell •

2) touch •

3) hear •

4) see •

5) taste •



2 Look and circle.

أنظر و ضع دائرة حول الإجابة الصحيحة.



mouth



nose



hand



eyes



ears



mouth



ears



mouth

لا تفسد الاشتراك في
قنوات ذاكرولي
على تطبيق التليجرام



mouth



hand

3 Look and choose.

أنظر واختر

1) I smell with my (nose



- mouth



).

2) I taste with my (mouth



- eyes



).

3) I see with my (eyes



- nose



).

4) I touch with my (hands



- eyes



).

5) I hear with my (ears



- nose



).

4 Look and match.

أنظر و صل.



Lesson 6

Phonics

B b

Trace

B B B B B B B

b b b b b b b

Write

1 2 3 B

1 2 b

Find B / b

O b M k o B

d b w u M R

b u B o A B

Color



Book

Words



bye!

بای بای



blue

أزرق



brown

بنی

H h

Trace

H H H H H H H H H H

h h h h h h h h h h

Write

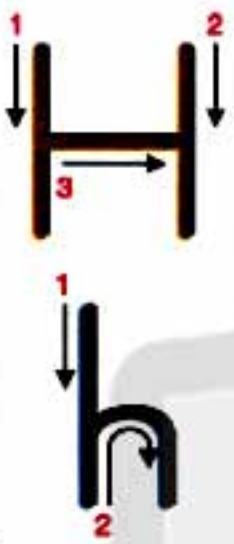

H

h

Find H / h

H b N k n h

d n H v J Q

u h s n H N

Color



Hat

Words



hair

شعر



hand

يد



hello!

مرحبا

Unit 1

Activities

1 Match.

صل.

1) bee •



2) bag •

3) blue •

4) hand •

5) hair •

6) hello •



2 Look and circle.

أنظرو وضع دائرة حول الإجابة الصحيحة.

1



b / h ag

2



b / h and

3



b / h ee

4



b / h air

5



b / h lue

6

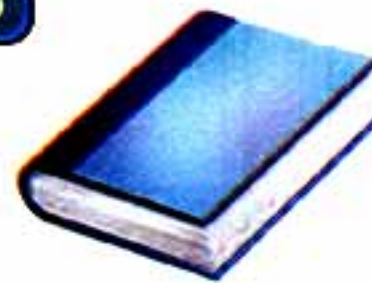

b / h ook

3 Trace, copy and say.

تتبع النقط و قل.



bag

bag

- ag



bee

bee

- ee



hair

hair

- air



hand

hand

- and

4 Trace.

تتبع.



bye

Hello

brown

bye

Hello

brown

Unit 1

5 Color pictures that begin with / h /.

لون الصور التي تبدأ بصوت (h)

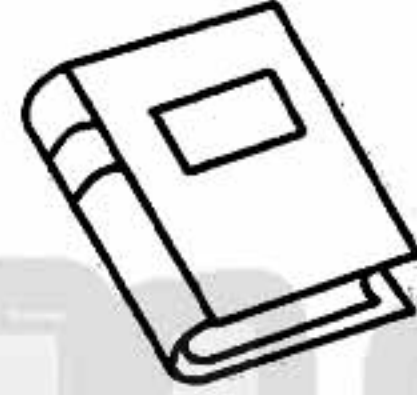
**6** Color pictures that begin with / b /.

لون الصور التي تبدأ بصوت (b)

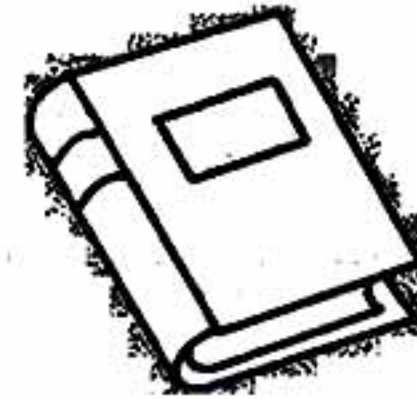

Lesson 7

What color is it ?

Objectives SB P. (12) / AB P. (12)

- ♦ To identify vocabulary for colors. - للتعرف على الألوان.
- ♦ To use colors to describe things. - لاستخدام الألوان لوصف الأشياء.
- ♦ To ask and answer question "What color is it?" - ما هو لونه ؟

Colors

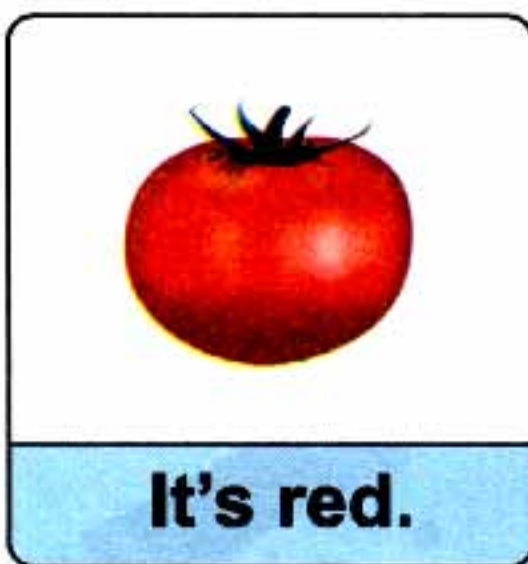

Unit 1

Language Use

1 ♦ What color is it?

- تستخدم للسؤال عن لون الأشياء (ما لونها؟)

♦ It's

- للإجابة وإعطاء اللون.

What color is it?



It's orange.



What color is it?



It's brown.



Activities

1 Match.

صل.

1) red •



2) blue •



3) yellow •



4) green •



5) orange •



6) brown •

2 Look and circle.

أنظرو وضع دائرة حول الإجابة الصحيحة.

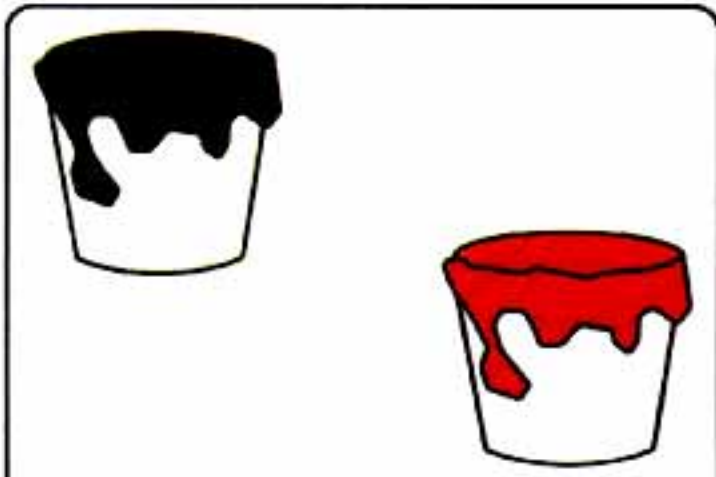

red

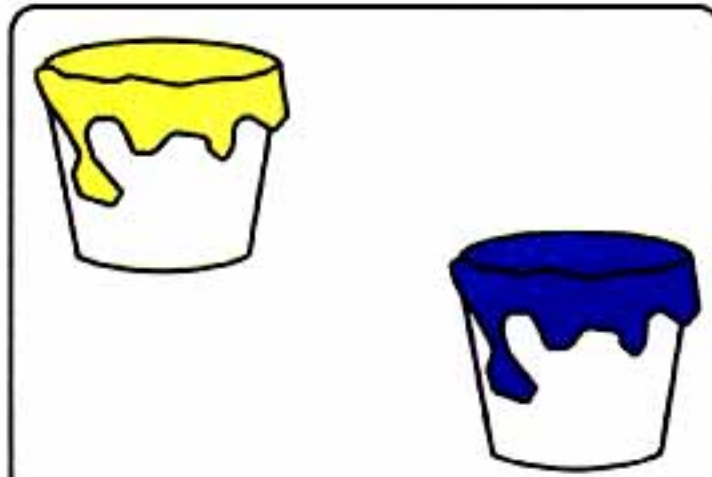

blue

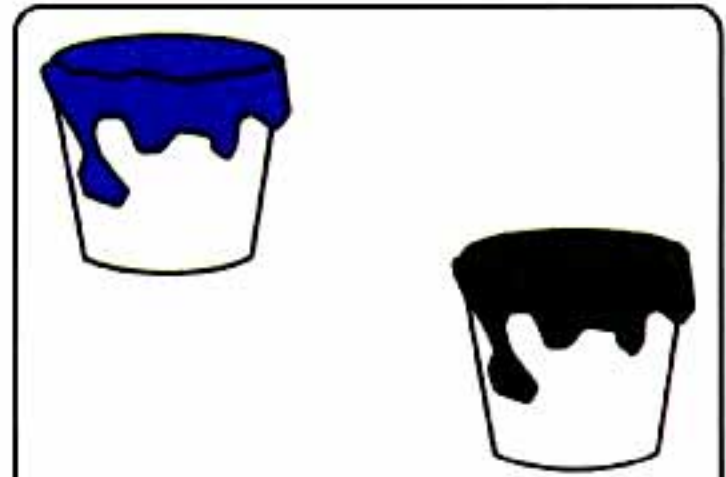

green

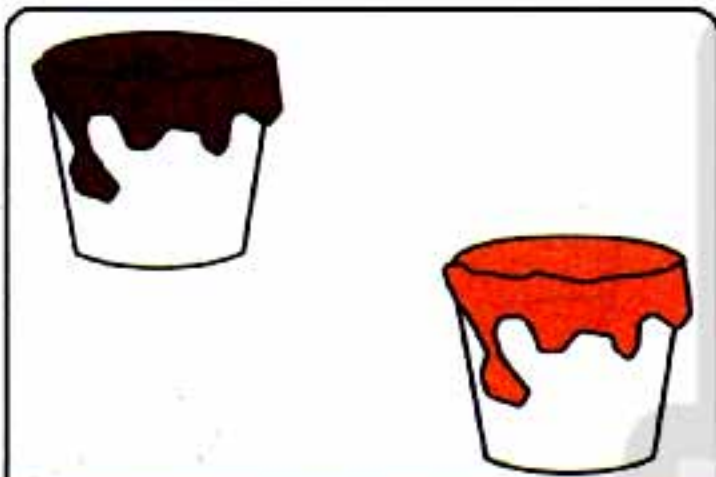

orange

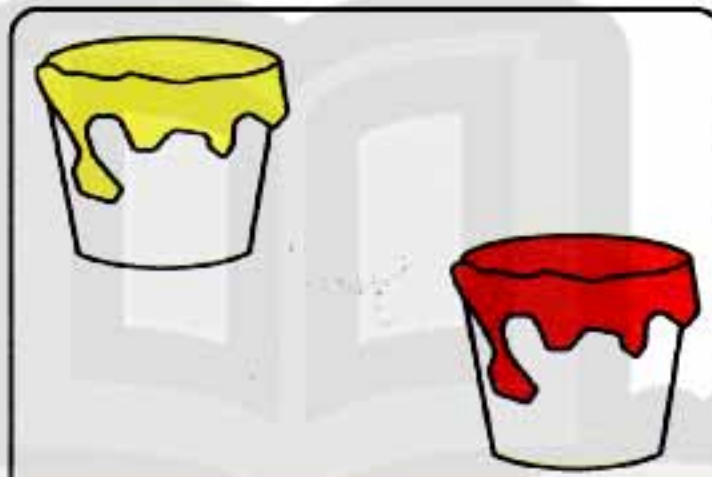

yellow

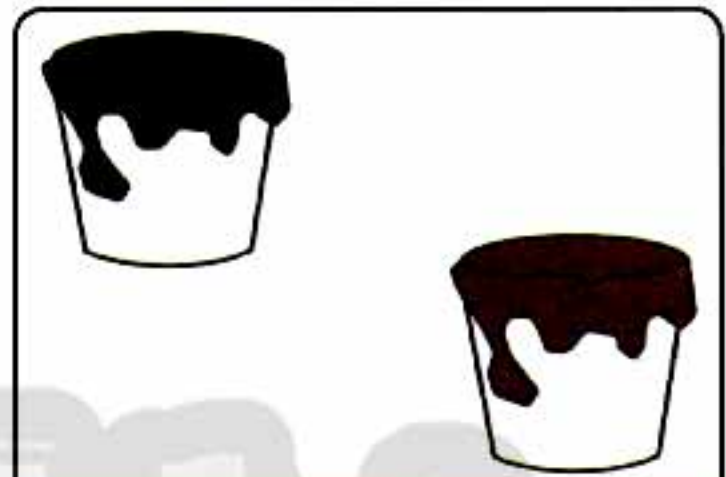

brown

3 Look and tick (✓).

أنظرو وضع علامة (✓).

1) It's red.



Yes

No

2) It's green.



3) It's orange.



4) It's blue.



5) It's yellow.



6) It's brown.



Unit 1

4 Color.

لون.

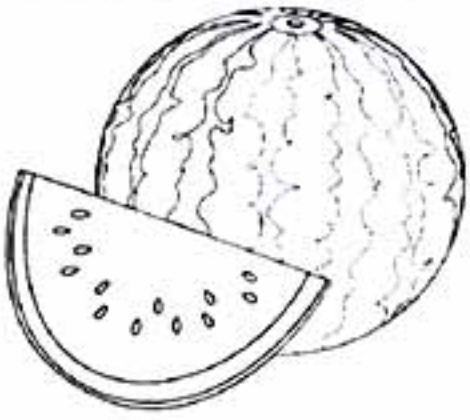

green



red



yellow

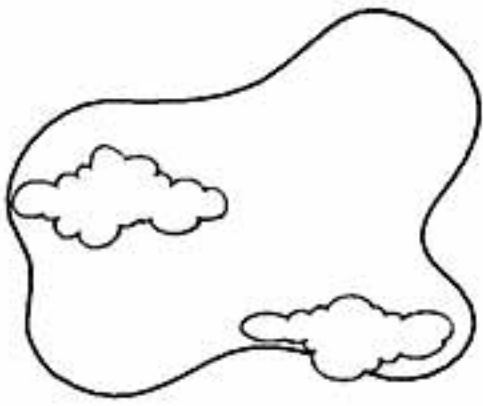

blue

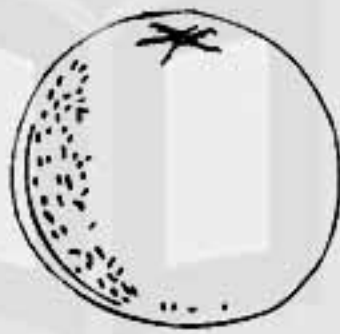

orange



brown

5 Look and tick (✓) the right answer.

أنظرو وضع علامة (✓).

What color is it?

1

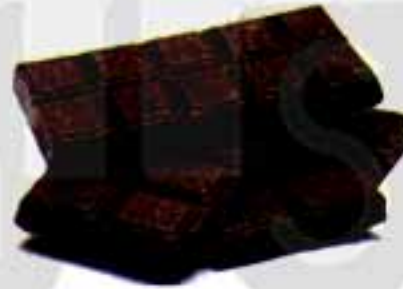
 It's brown. It's red.

What color is it?

2

 It's blue. It's yellow.

What color is it?

3

 It's red. It's green.

What color is it?

4



It's brown.

It's green.

What color is it?

5



It's blue.

It's red.

6 Color.

نقومه في أي عمل عليه العلامة ري ذاكروولى

لون.

red

yellow

orange

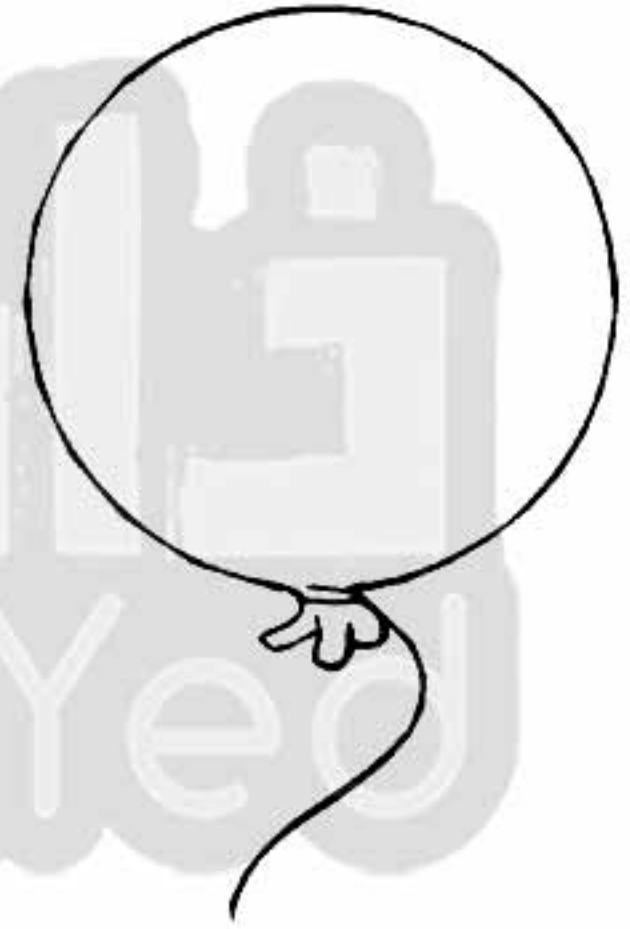
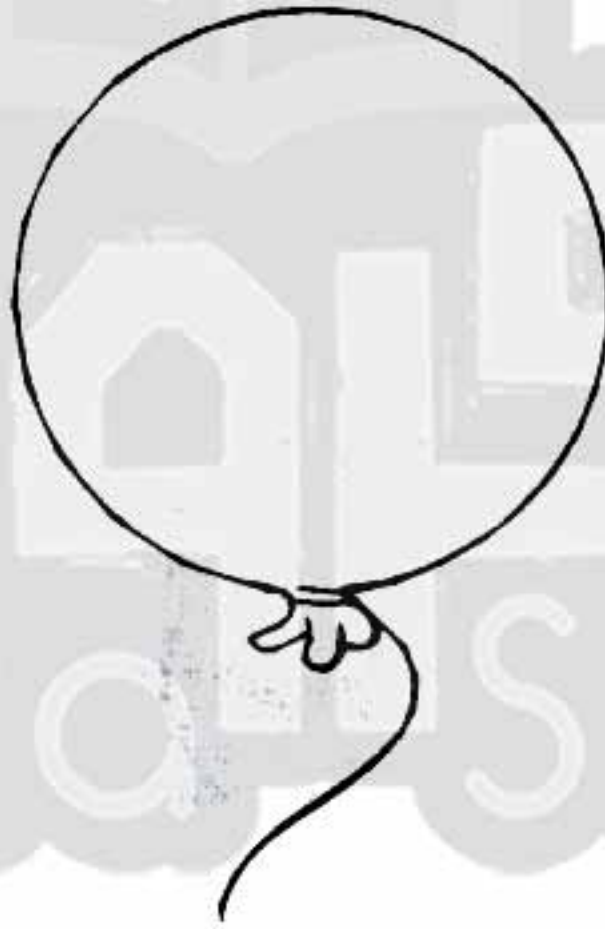

blue

green

brown

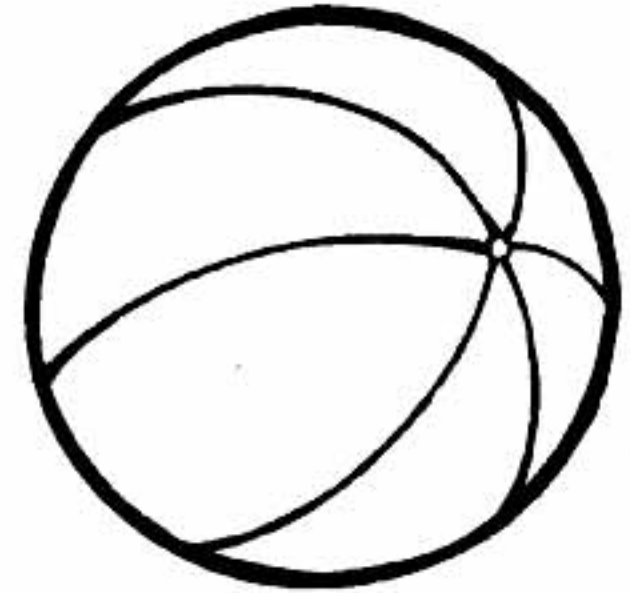
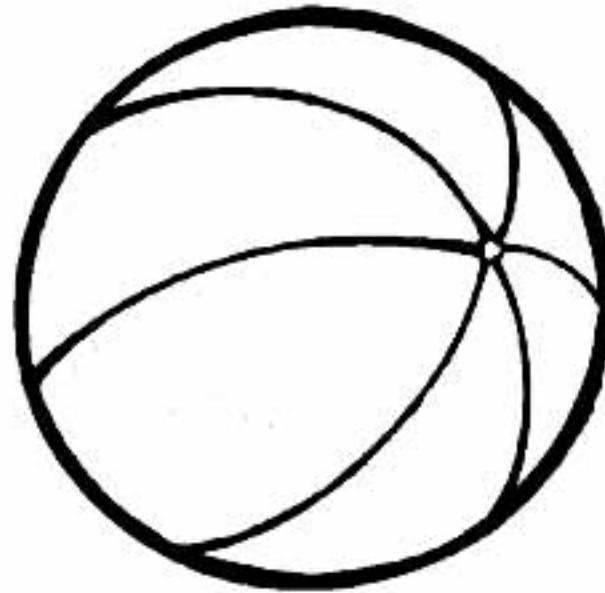
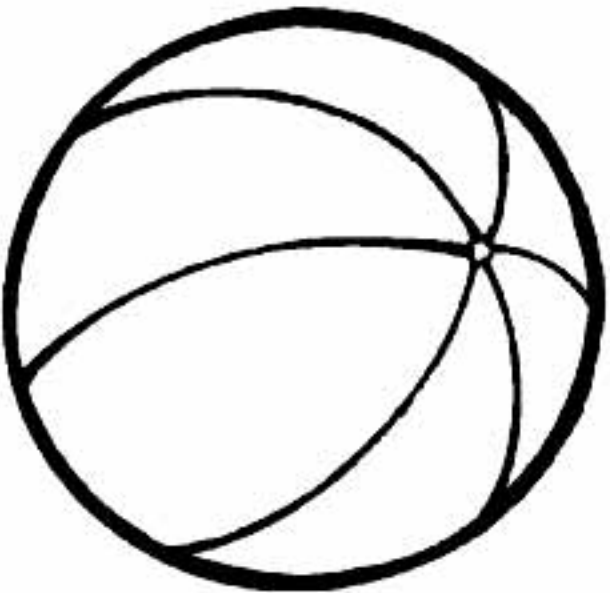

Lesson 8

I like green

Objectives SB P. (13 – 14) / AB P. (14 – 15)

- ◆ To use vocabulary for colors. - لاستخدام الكلمات الخاصة بالألوان.
- ◆ To talk about their favourite colors. - للحديث عن الألوان المفضلة لديهم.

Note

I like

تستخدم عندما تتحدث عن شيء تحبه



I like green. أنا أحب الأخضر.



I like blue. أنا أحب الأزرق.

This is my balloon.
It's for MommyThis is my balloon.
It's for Daddy

A new color



Red and yellow
make orange.



Blue and yellow
make green.

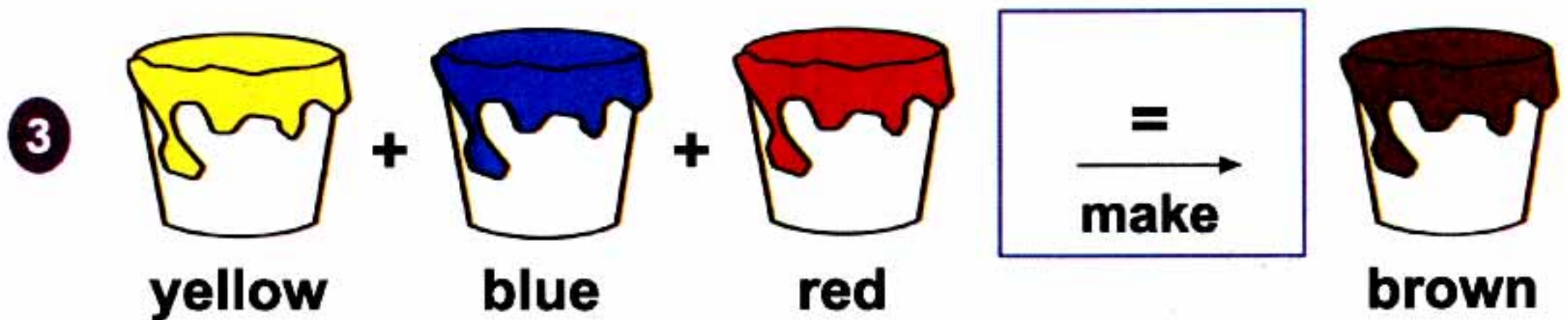

Unit 1

Activities

1 Look and tick (✓).

أنظر و ضع علامة (✓).

1) It's red.



Yes

No

2) It's green.



3) It's orange.



4) It's brown.



5) It's blue.



6) It's yellow.

**2** Read and color.

أقرأ و لون.

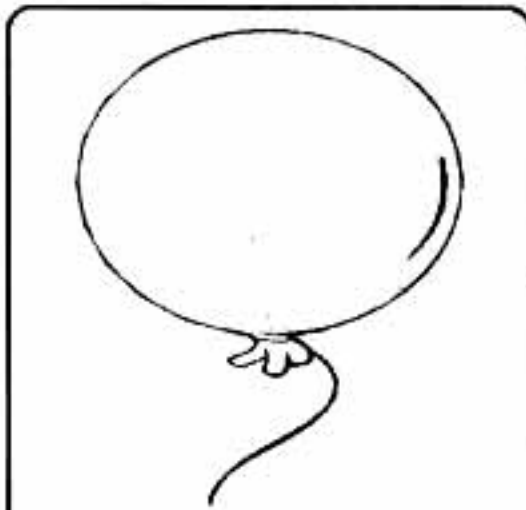

I like red.

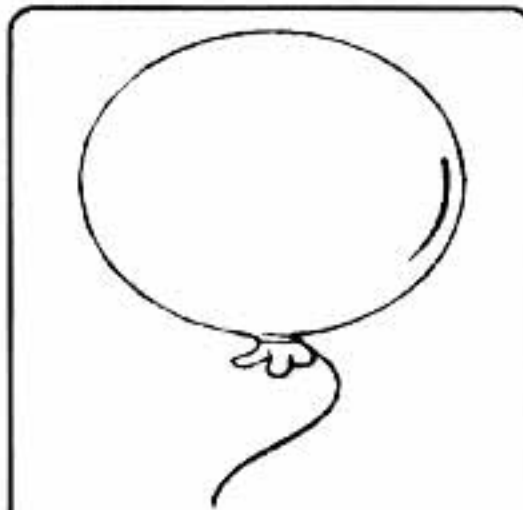

I like green.

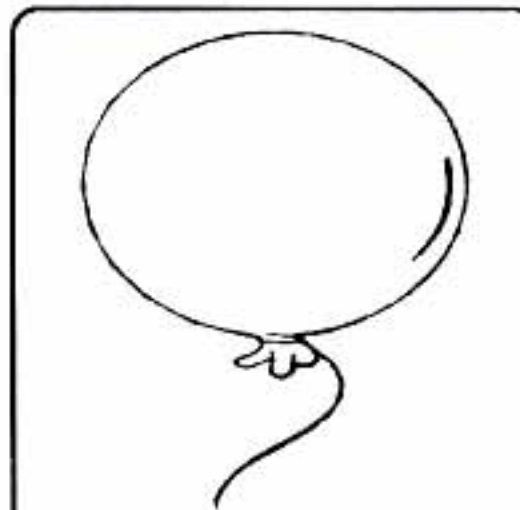

I like blue.

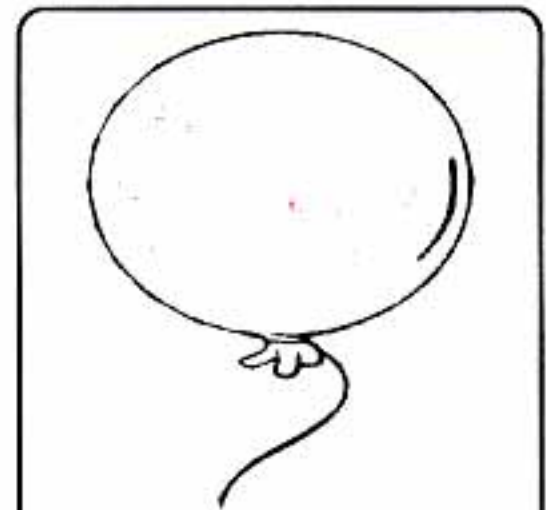

I like yellow.

Writing corner



mommy



daddy



sister



brother



eye

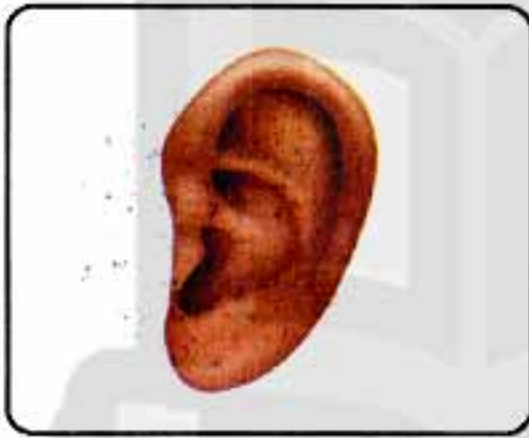

ear



mouth



hair



arm



leg



foot

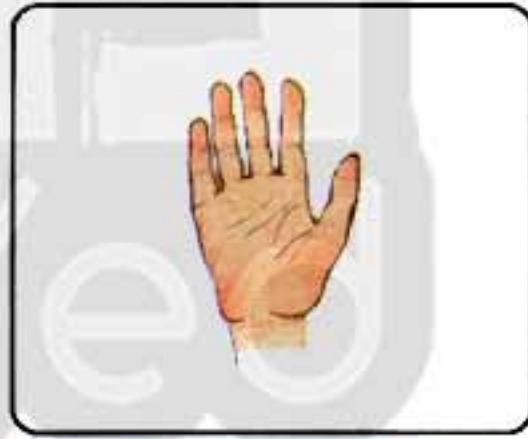

hand



face

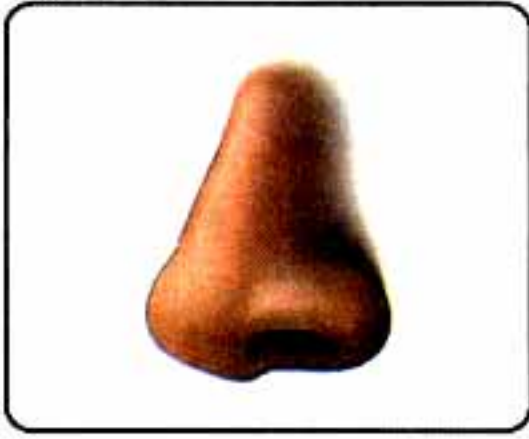

nose

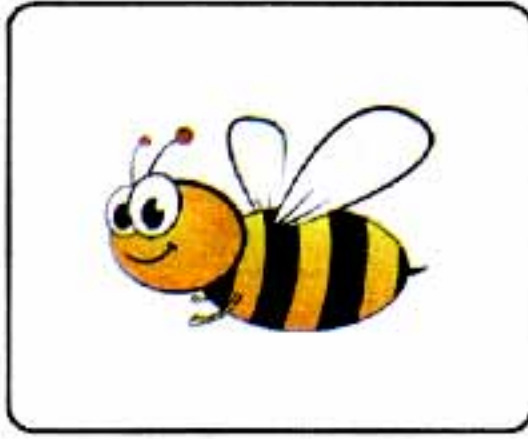

bee



bag

Unit 1

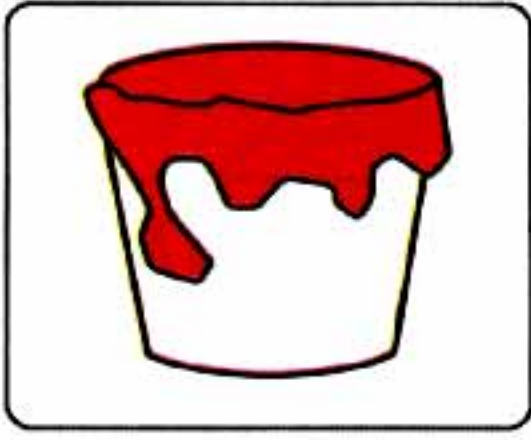

red

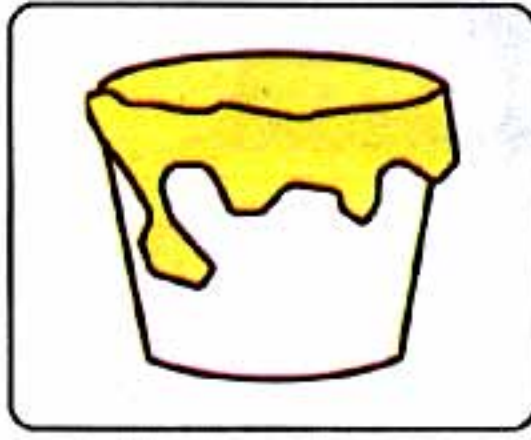

yellow

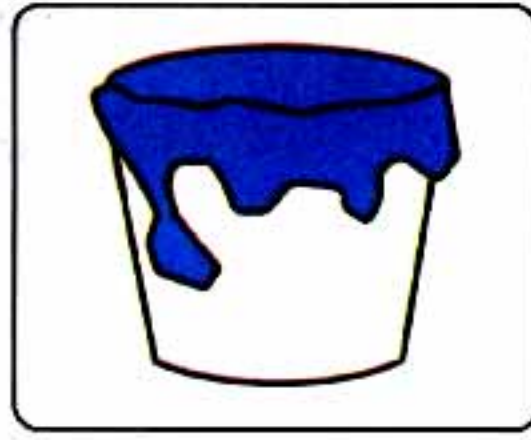

blue

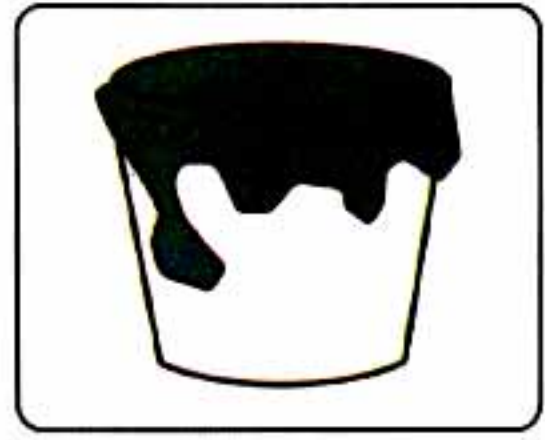

green

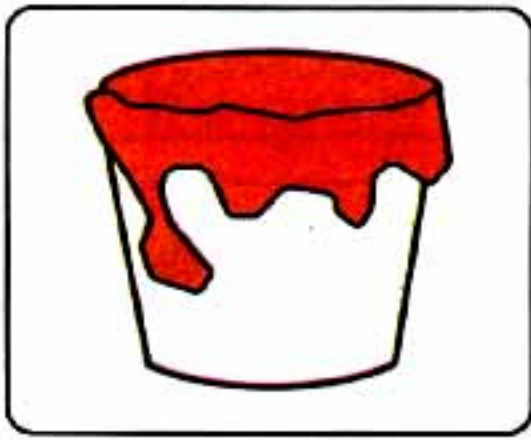

orange

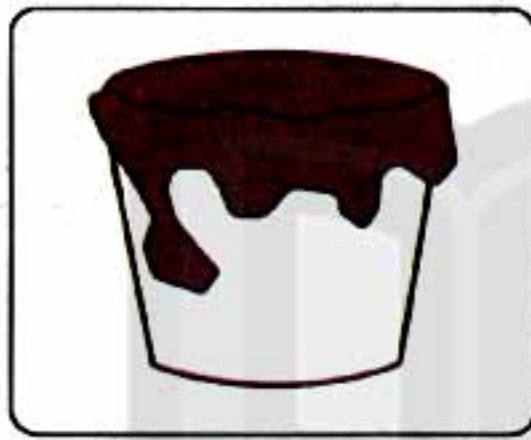

brown

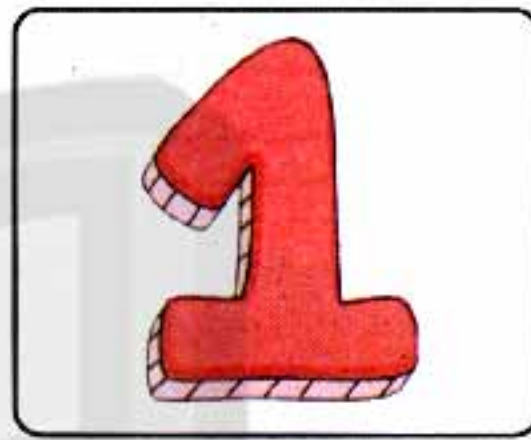

one

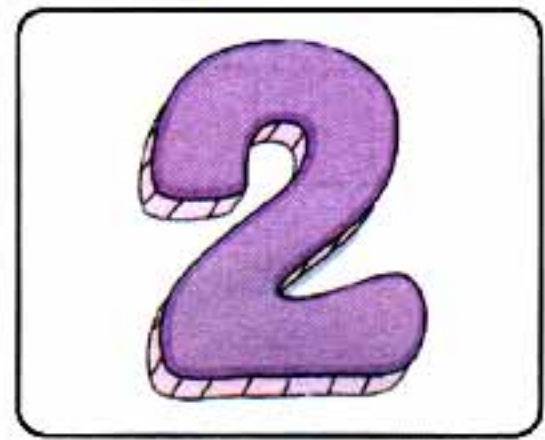

two



This is my family

In my classroom



Vocabulary

- ◆ pencil, pen, eraser, sharpener, board, chair, table.
- ◆ Numbers 1 – 10.
- ◆ circle, triangle, square, rectangle.
- ◆ teacher, librarian, nurse.

Language

- ◆ This is a (pen).
- ◆ This is an (eraser).
- ◆ How many are there?
- ◆ It's a circle.

Phonics

- ◆ / M / math, classroom.
- ◆ / N / nose, nurse, pen.

Values

- ◆ Collaboration.
- ◆ Independence.

Integrated cross-curriculum topics

- ◆ Social sciences : People who help us.
- ◆ Math : Shapes.
- ◆ Art : make a shape pictures.

Lesson 1

Vocabulary , Reading
and speaking

Objectives SB P. (20 – 23) / AB P. (18 – 20)

- ◆ To identify and use vocabulary for school objects.
- للتعرف على استخدام الكلمات الخاصة بالأدوات المدرسية.
- ◆ To ask and answer question "What is this?".

School objects

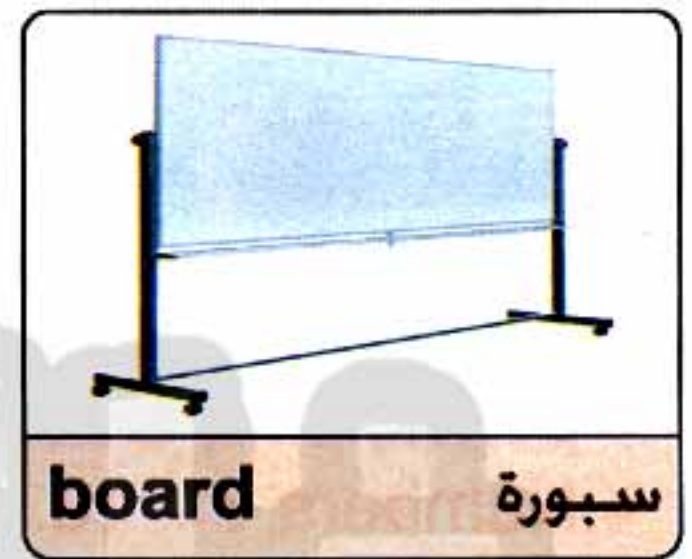
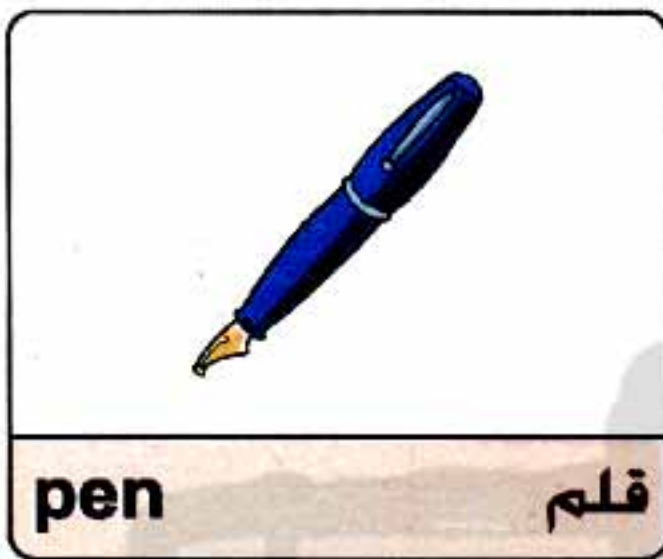

Notes

نضيف للكلمة التي تبدأ بحرف متحرك **an** , والحروف المتحركة هي :

(a – e – o – i – u)

an apple 

an egg 

an orange 

an ice cream 

an umbrella 

Language Use

1 ♦ What is this?

- تستخدم للسؤال عن الأشياء (ما هذا ؟) .

♦ This is

- تستخدم للتعريف بالأشياء .

What is this?



This is a pen.



What is this?



This is a pencil.



What is this?



This is a board.



What is this?



This is a sharpener.



What is this?



This is a table.



What is this?



This is an eraser.



Unit 2

Activities

1 Match.

تفوقه في أي عمل عليه العلامة ري

صل.

- 1) pen
- 2) pencil
- 3) sharpener
- 4) eraser
- 5) board
- 6) table



2 Look and circle.

أنظر و ضع دائرة حول الإجابة الصحيحة.

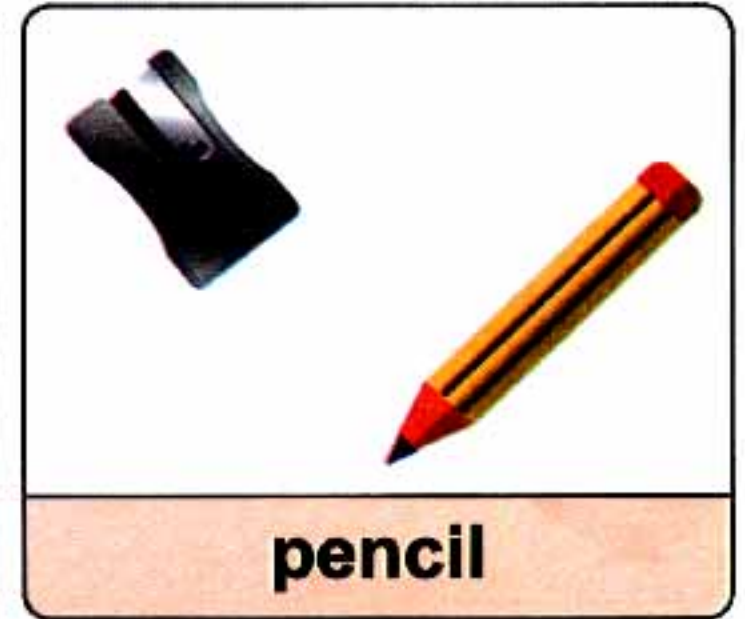
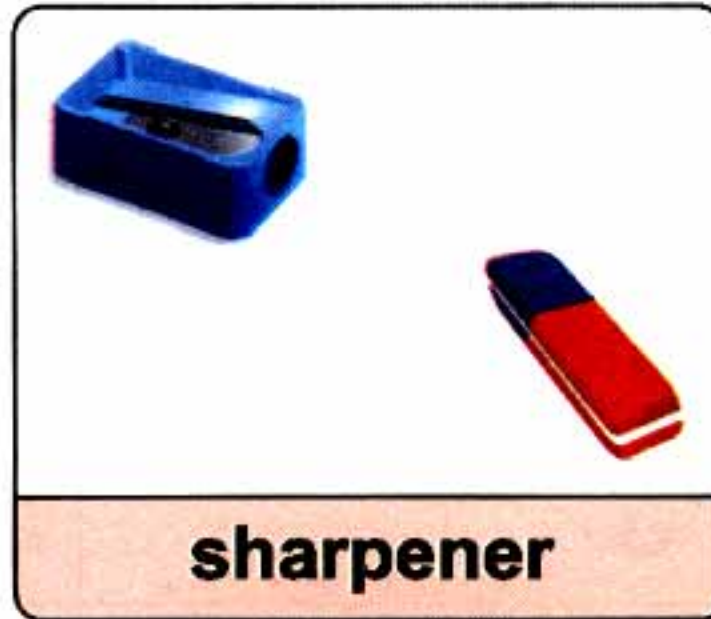
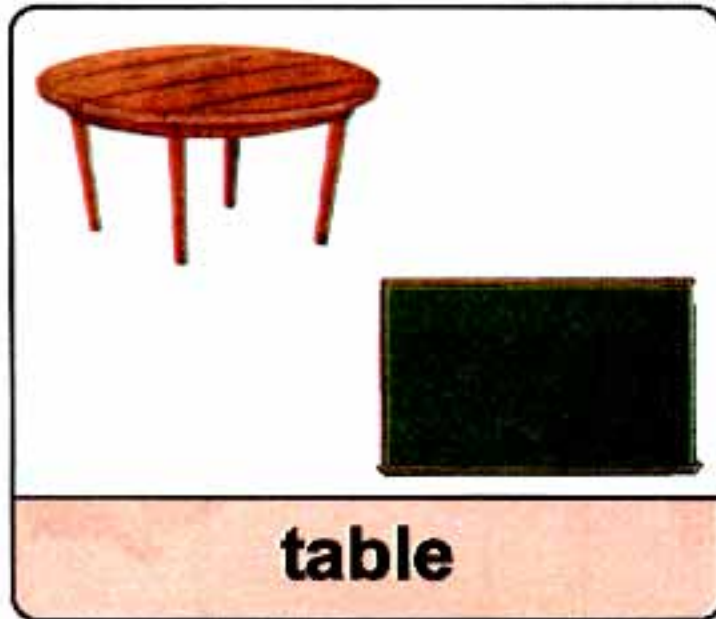
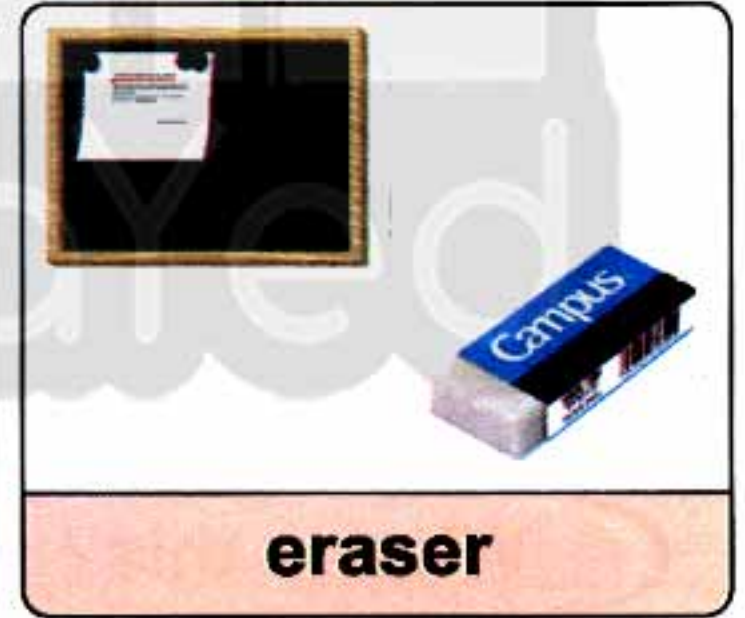
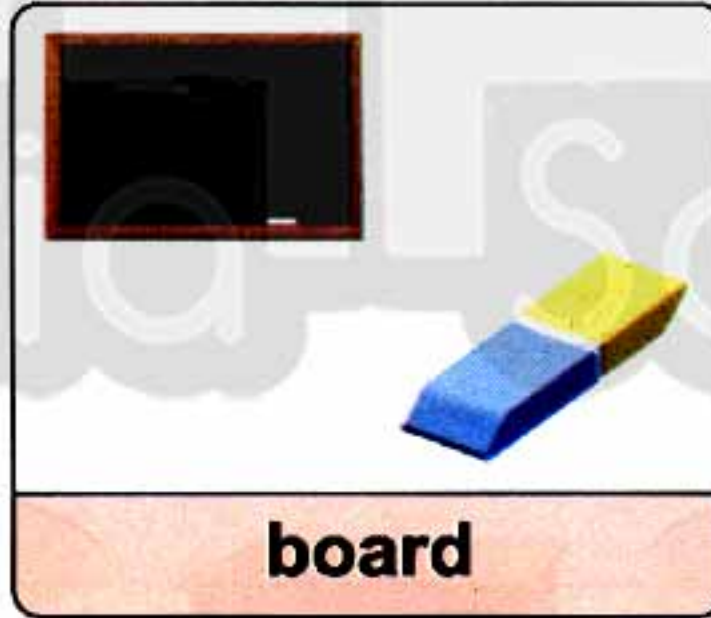
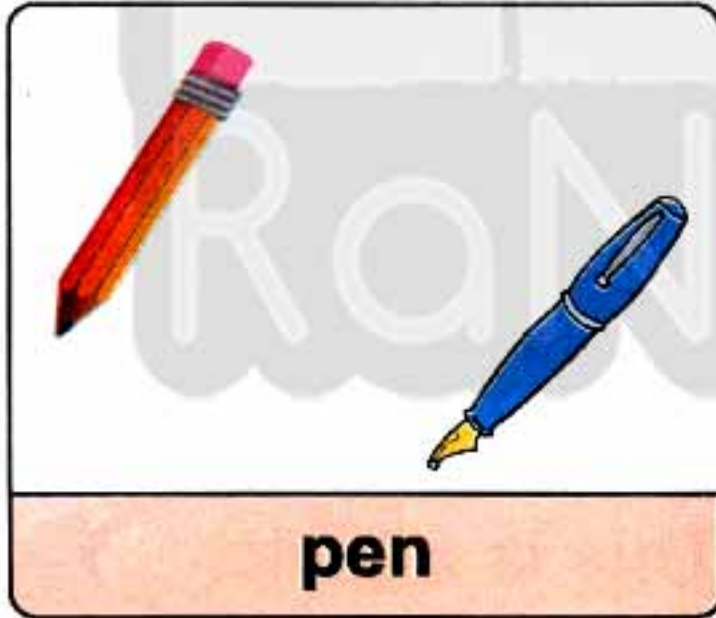

3 Look and tick (✓).

أنظر و ضع علامة (✓).

- 1) This is a pen.
- 2) This is a table.
- 3) This is an eraser.
- 4) This is a board.
- 5) This is a pencil.
- 6) This is a sharpener.



Yes	No
<input type="checkbox"/>	<input type="checkbox"/>
<input type="checkbox"/>	<input type="checkbox"/>
<input type="checkbox"/>	<input type="checkbox"/>
<input type="checkbox"/>	<input type="checkbox"/>
<input type="checkbox"/>	<input type="checkbox"/>
<input type="checkbox"/>	<input type="checkbox"/>

4 Trace and color.

تتبع النقط و لون.

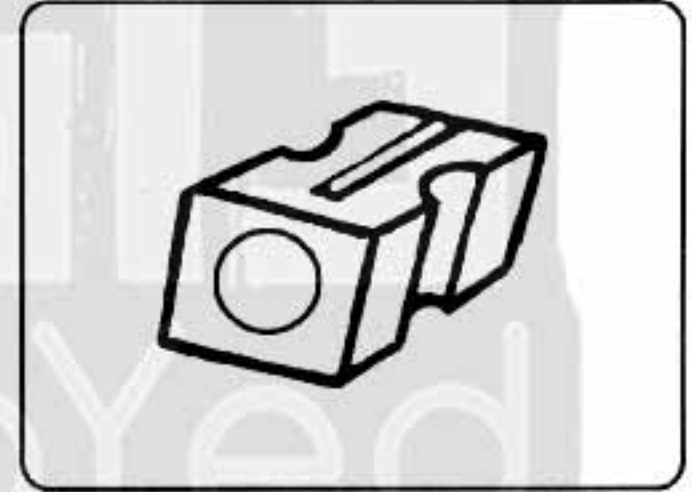
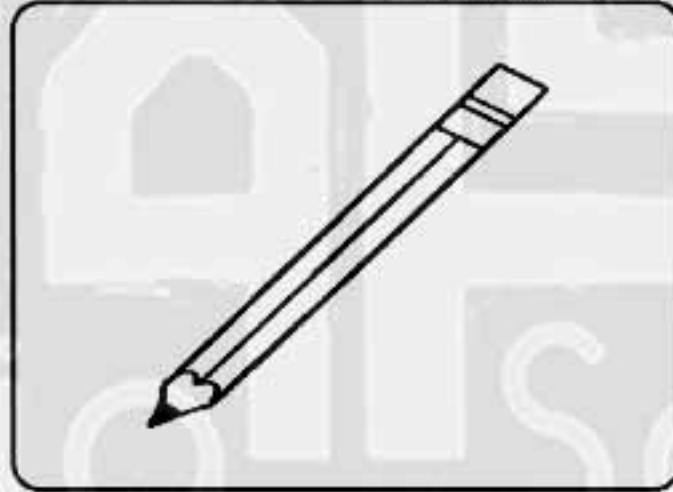

pen

pencil

sharpener

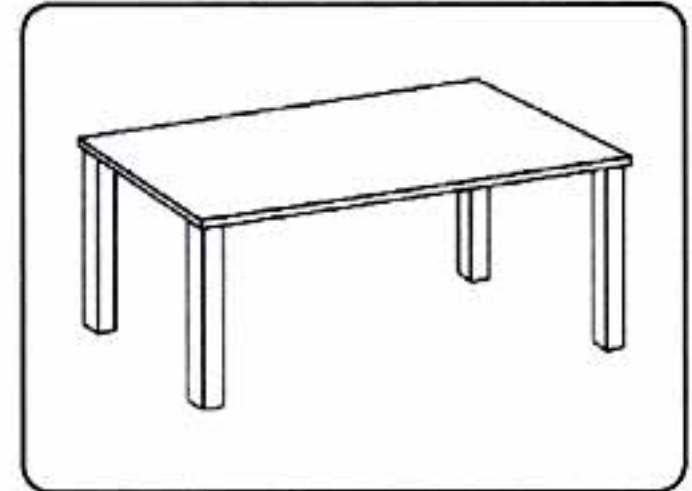
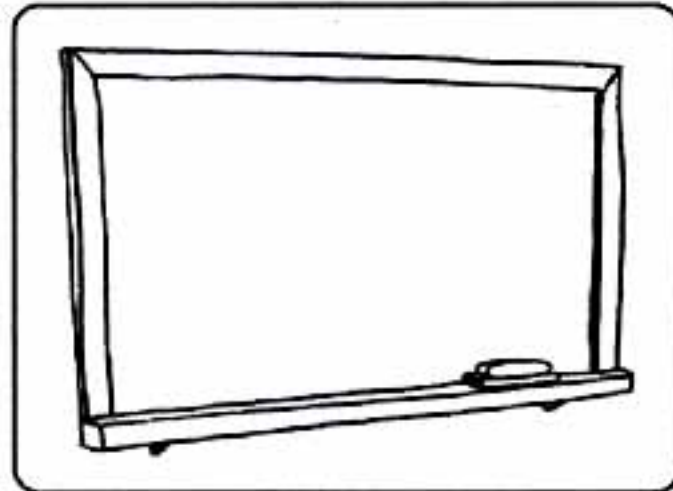
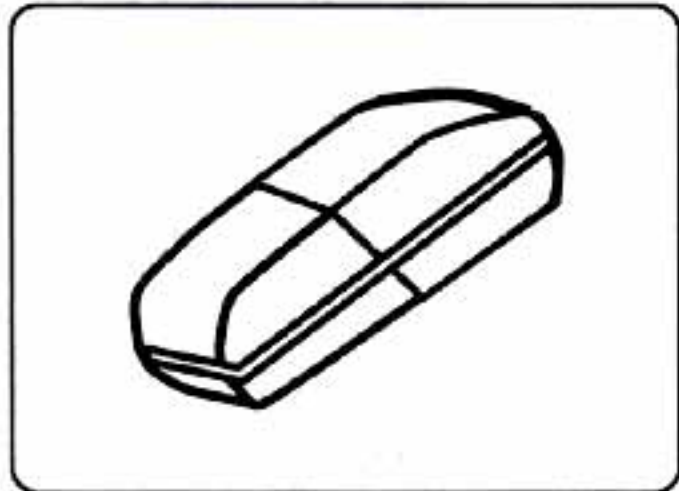

eraser

board

table

Unit 2

5 Look and tick (✓) the right answer. أنظرو وضع علامة (✓).

What is this?



- This is a pen.
 This is a pencil.

What is this?



- This is a board.
 This is a table.

What is this?



- This is a sharpener.
 This is an eraser.

What is this?



- This is a pencil.
 This is a board.

What is this?



- This is a sharpener.
 This is a board.

6 Color and say.

لون و قل.

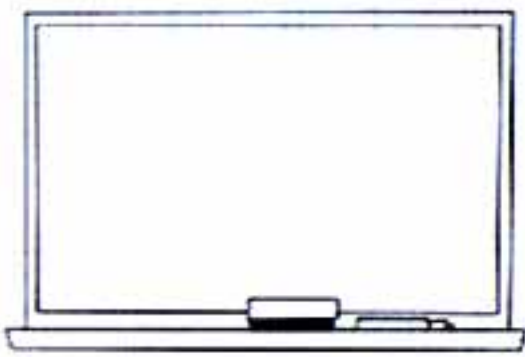
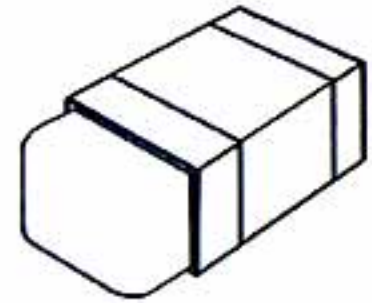









Lesson 2

I can count (connect with Math)

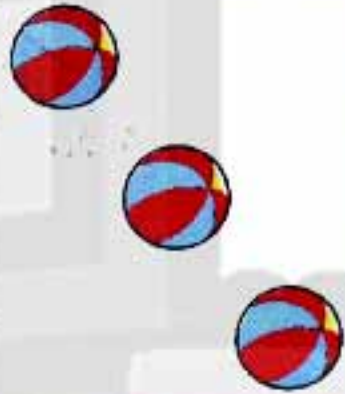
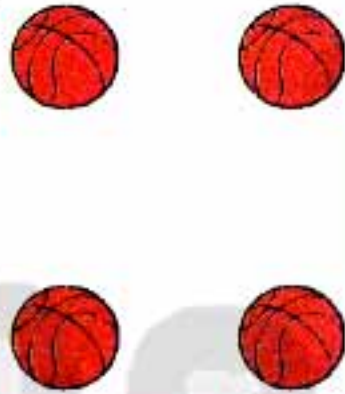
Objectives SB P. (23) / AB P. (21)

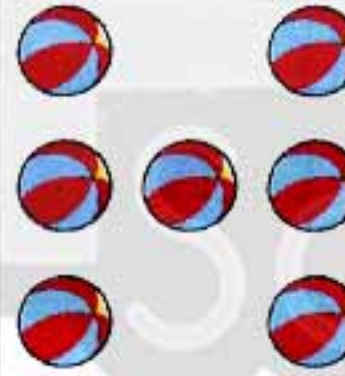
- To identify the numbers from 1 – 10.
- To use the numbers to count different items.
- To write the words for numbers 1 – 10.

Numbers

 1	 2	 3	 4
one	two	three	four
 5	 6	 7	 8
five	six	seven	eight
 9	 10		
nine	ten		

Unit 2

Activities

1 Match.

صل.

3

one

4

two

6

three

1

four

2

five

5

six

2 Count and trace.

عد و تتبع النقط.

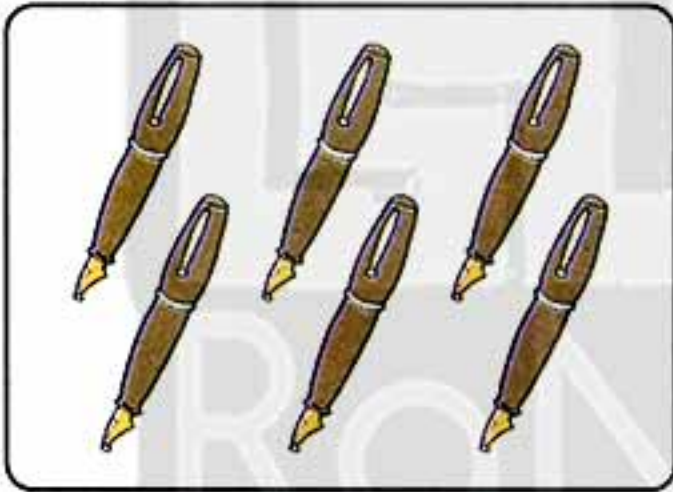

6



4



3



5

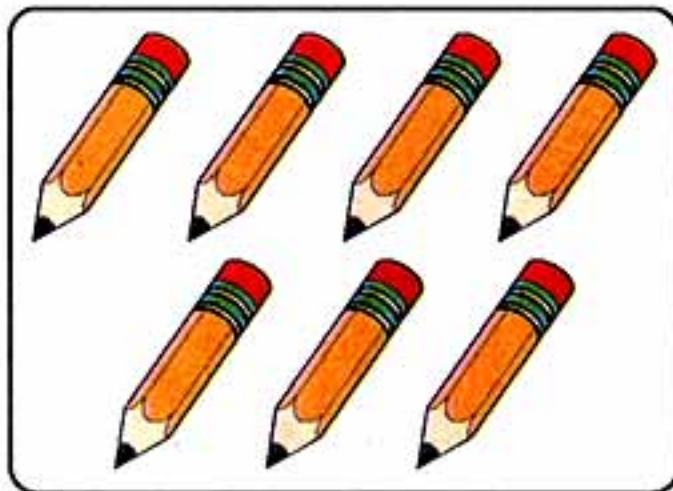

7

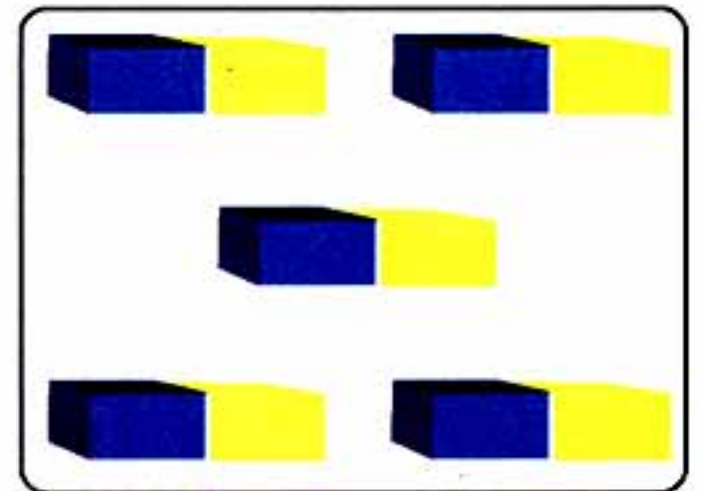

8

3 Count and circle.

عد و ضع دائرة.



1 2



3 4

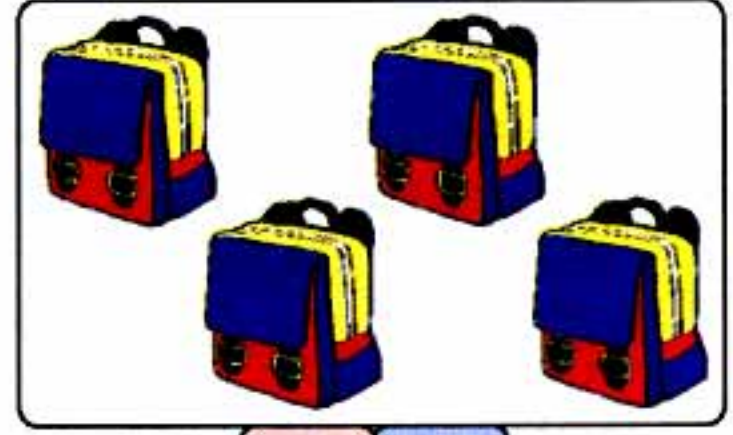

4 5

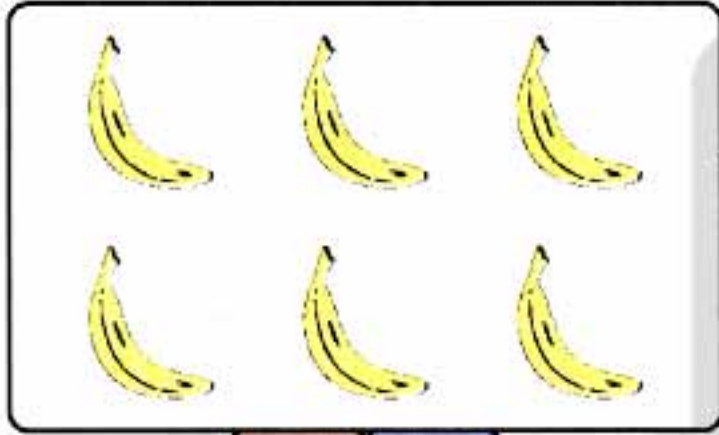

6 7

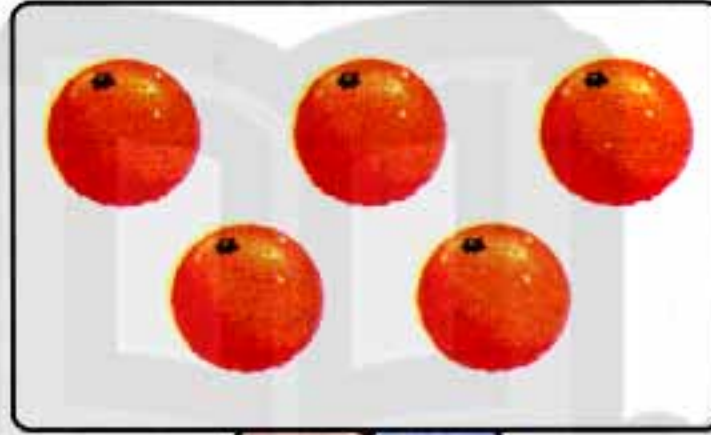

5 6



7 8

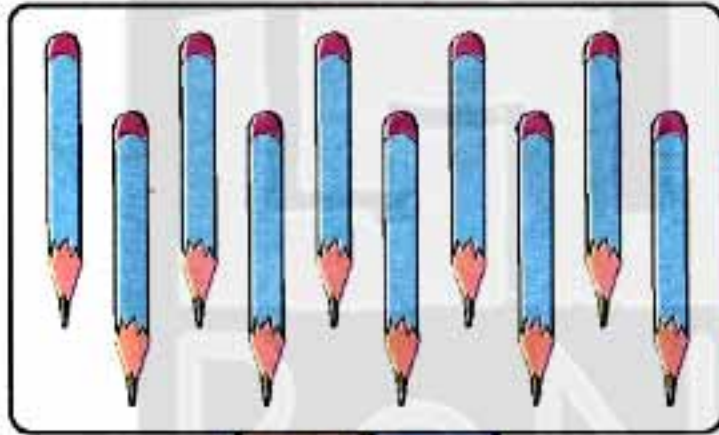

9 10

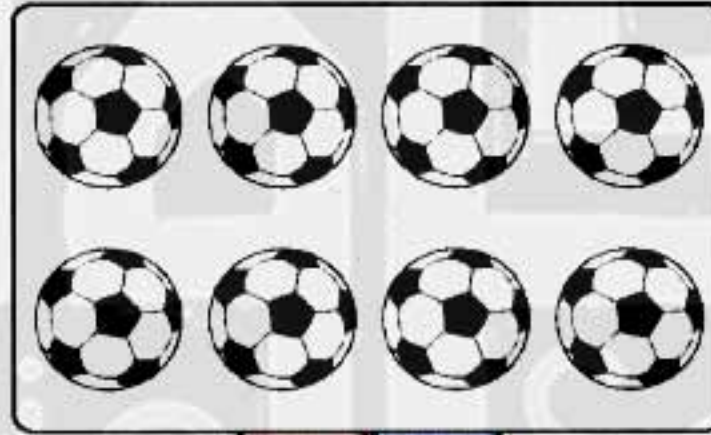

7 8

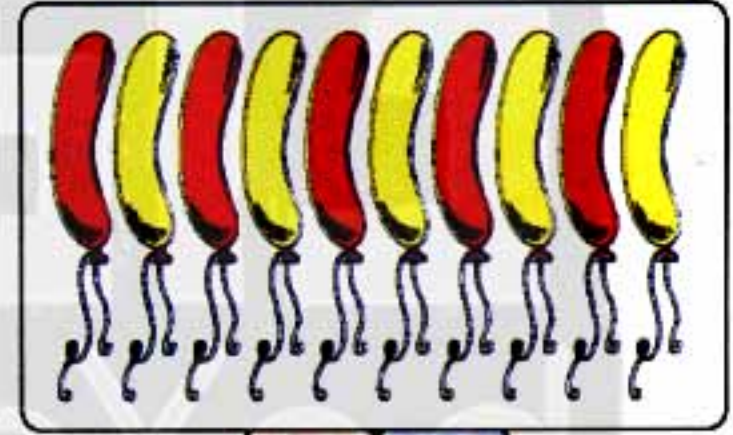

8 9

4 Trace and color.

تتبع النقط و لون.

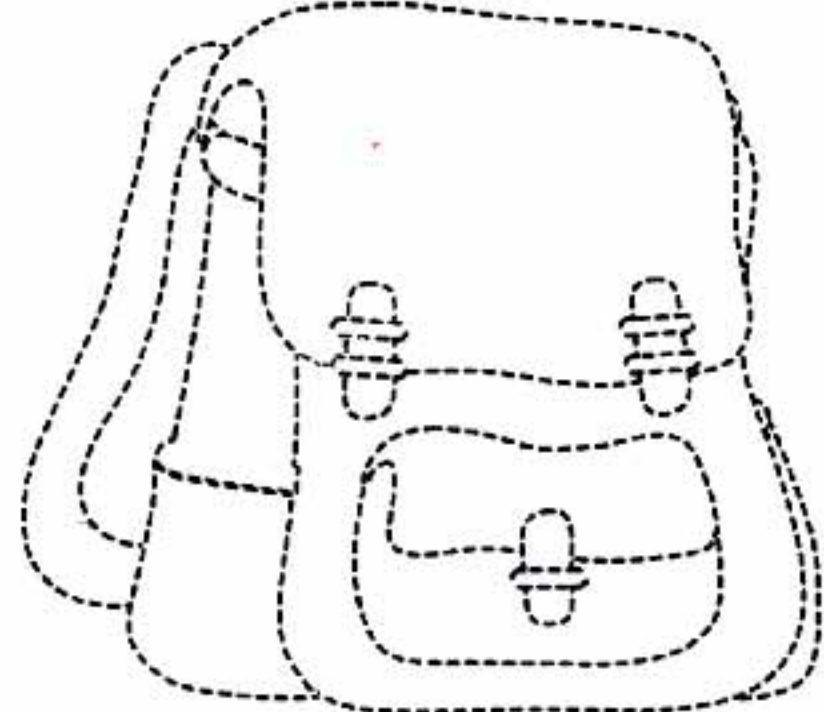

Unit 2

5 Look at the word and circle the correct number.

انظر إلى الكلمة وضع دائرة حول الرقم الصحيح.

three	
3	4

four	
5	4

seven	
6	7

nine	
9	10

two	
2	3

ten	
9	10

6 Color six balls only.

لون ست كرات فقط.

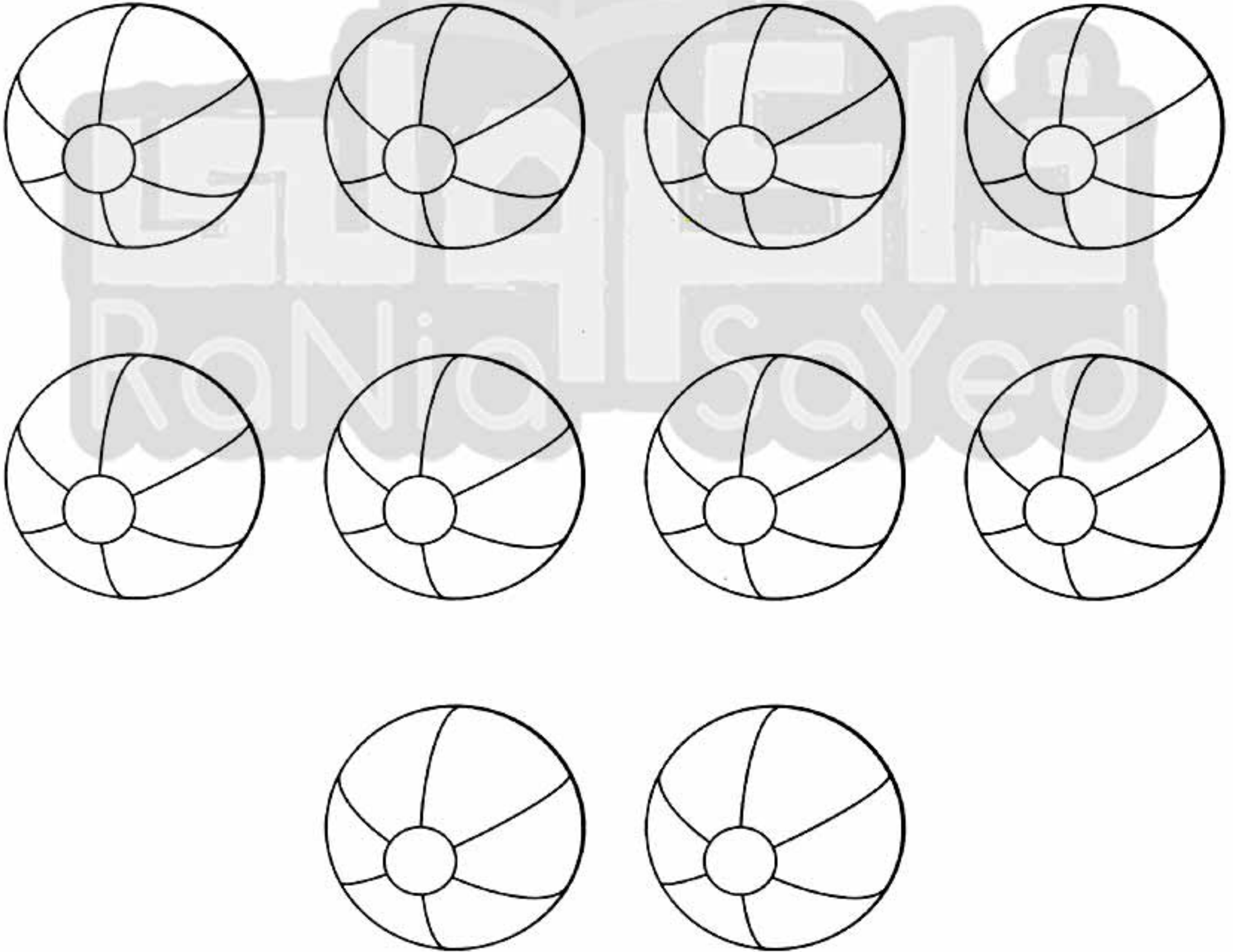





How many chairs are there?

Lesson 3







Objectives SB P. (24) / AB P. (22)

- ◆ To use numbers with vocabulary of school objects.
- ◆ To differentiate between **there is** / **there are**.
- ◆ To ask and answer question "How many?".

There is	مفرد
	
There is one pencil.	
	
There is one sharpener.	

There are	جمع
	
There are three pencils.	
	
There are four sharpeners.	

1 - تستخدم للسؤال عن عدد الأشياء. ◆ How many are there ?

	How many pencils are there?			There are five pencils.
	How many tables are there?			There is one table.

Unit 2

Activities

1 Match.

صل.

1) There are two chairs. •



2) There are three tables. •



3) There are five pencils. •



4) There is one board. •



5) There are five erasers. •



2 Read and circle the correct answer.

أقرأ و ضع دائرة.

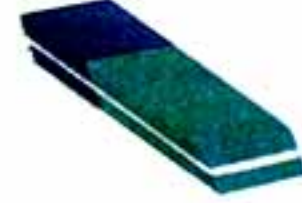
1) There (**is** – **are**) four pens.2) There (**is** – **are**) one eraser.3) There (**is** – **are**) one sharpener.4) There (**is** – **are**) three pencils.

3 Count and circle.

عد و ضع دائرة.



There are (two / three) chairs.



There are (four / five) pencils.



There are (five / six) eraser.



There are (nine / ten) pens.

4 Look and tick (✓) the right answer.

أنظر و ضع علامة (✓).

How many pencils are there?

 There are five. There are six.

How many sharpeners are there?

 There are seven. There are eight.

How many pens are there?

 There are three. There are four.

How many erasers are there?

 There are nine. There are ten.

Lesson 4

Learn shapes with Busy Bee!
(connect with Math)

Objectives SB P. (25 – 26) / AB P. (23 – 25)

- To identify vocabulary for shapes. التعرف على الأشكال الهندسية المختلفة.
- To differentiate between the different shapes. للتمييز بين الأشكال المختلفة.

Shapes

triangle مثلث

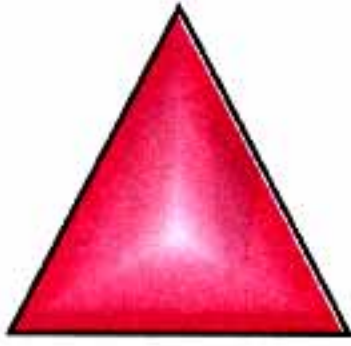

A **triangle** has **three** sides.
المثلث لديه ثلاث جوانب

circle دائرة

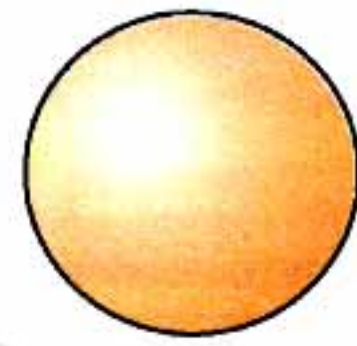

A **circle** is **round**.
الدائرة تكون مستديرة.

square مربع



A **square** has **four** equal sides.
المربع لديه اربع جوانب متساوية.

rectangle مستطيل



A **rectangle** has **two** short sides and **two** long sides.
المستطيل لديه ٢ جانب قصير و٢ جانب طويل.



The eraser is a rectangle.

The sharpener is a circle.



Activities

1 Match.

صل.

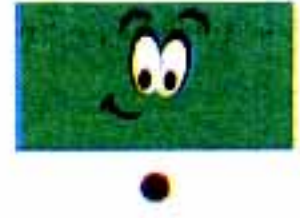
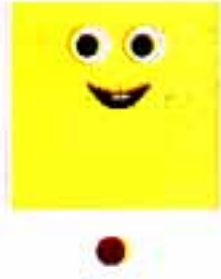
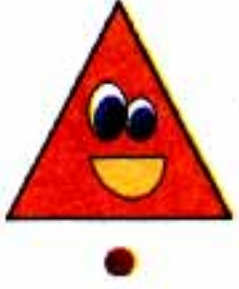

rectangle

square

triangle

circle

2 Look and circle.

أنظر و ضع دائرة حول الإجابة الصحيحة.



rectangle



triangle



circle



square

3 Count, color and say.

عد و لون و قل.

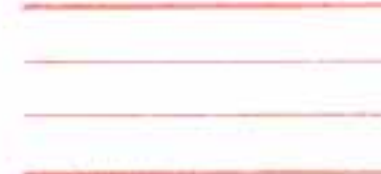
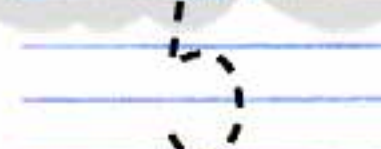
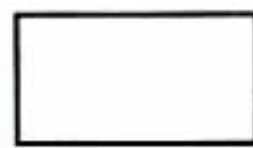
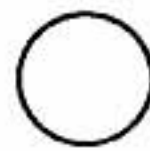
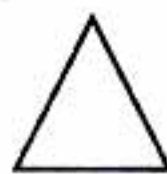
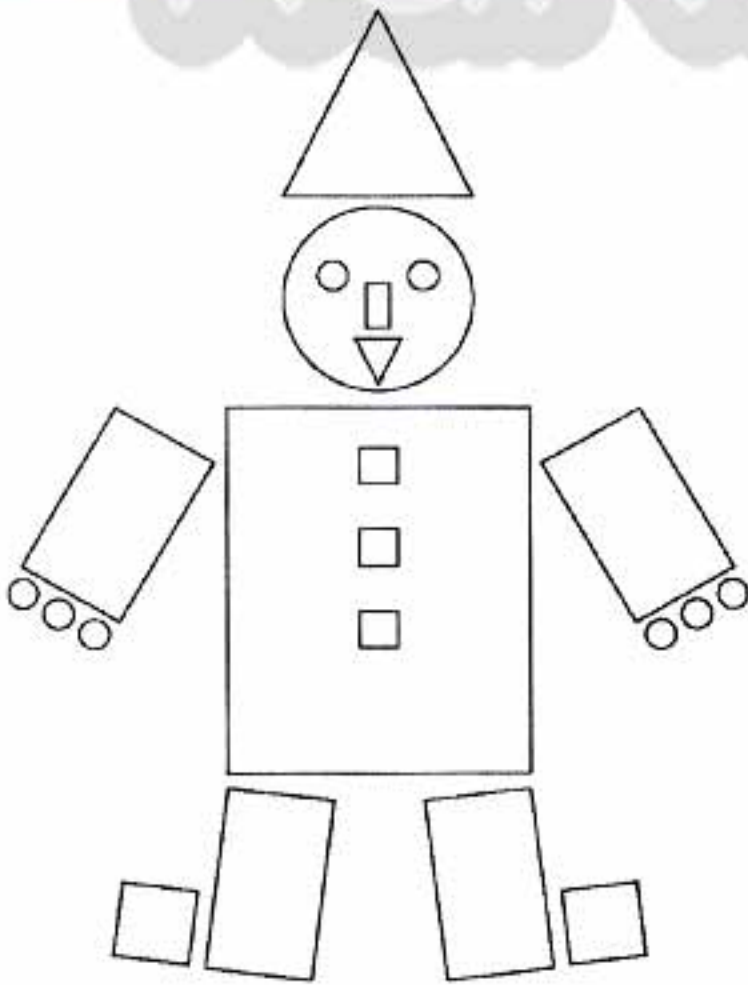

Unit 2

4 Look and tick (✓).

أنظر و ضع علامة (✓).

- 1) It has three sides.
- 2) It has four sides.
- 3) It has three short sides.
- 4) It is round.

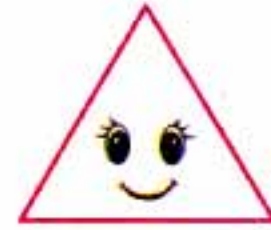

Yes

No

5 Trace and color.

تتبع النقط و لون.

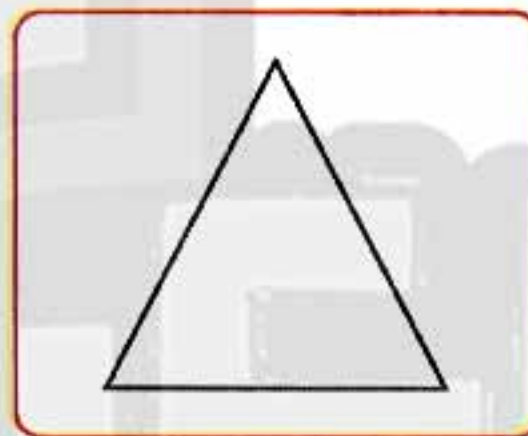
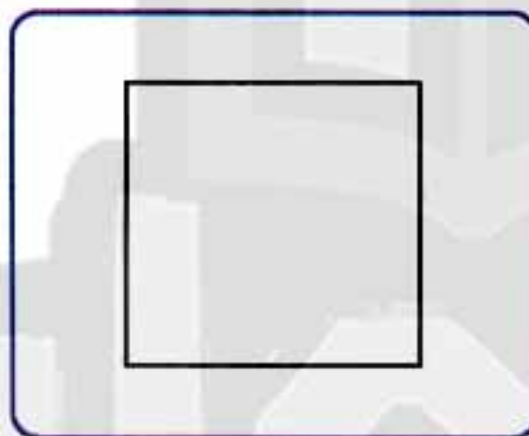
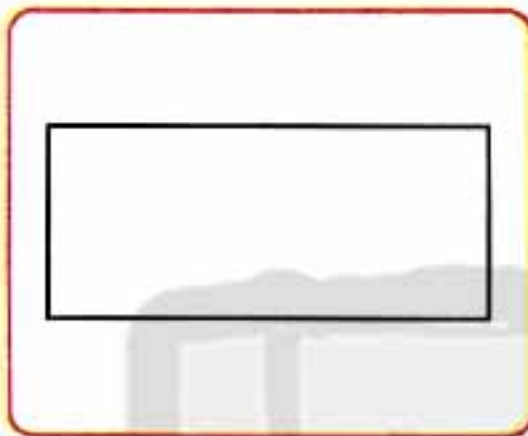

rectangle

square

triangle

circle

6 Choose.

تتبع النقط و لون.

- 1) The eraser is a



circle

-



rectangle



- 2) The table is a



triangle

-



square



- 3) The sharpener is a



circle

-

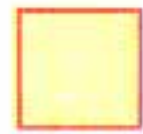

square



- 4) The board is a



circle

-



rectangle



Lesson 5

Phonics

M m

Trace

M M M M M M M M

m m m m m m m m

Write

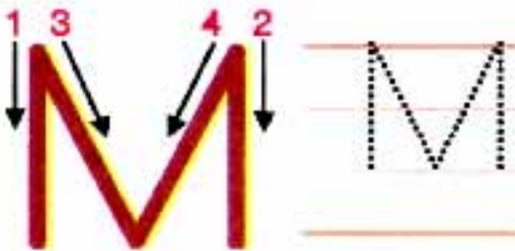

M



m

Find M / m

N b M k m Q
d m w v M R
S u B m A M

Color

mouth



Words



mouth

فم



Maha

مها



classroom

فصل

Unit 2

N n

Trace

N N N N N N N N

n n n n n n n n

Write

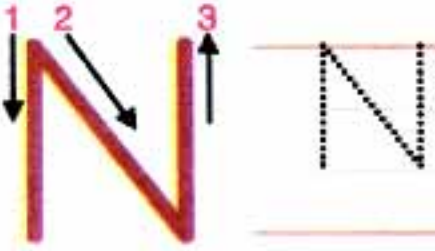

N



n

Find N / n

C	b	N	k	n	R
d	n	w	v	N	Q
S	u	B	n	A	N

Color



nurse

Words



nurse

مرضة



Nour

نور



pen

قلم جاف

Activities

1 Match.

صل.

1) Maha •



2) classroom •



3) mouth •



4) pen •



5) nurse •



2 Look and circle.

أنظر و ضع دائرة حول الإجابة الصحيحة.

1



m / n urse

2



m / n outh

3



pe m / n

4



classroo m / n

5



M / N aha

6



M / N our

Unit 2

3 Put m or n.

ضع حرف m و n.



-urse



-outh



pe -



classroo -

4 Trace.

تتبع النقط.



classroom



pen



nurse



mouth

classroom

pen

nurse

mouth

5 Color words have / m /.

لون الكلمات التي بها حرف (m)

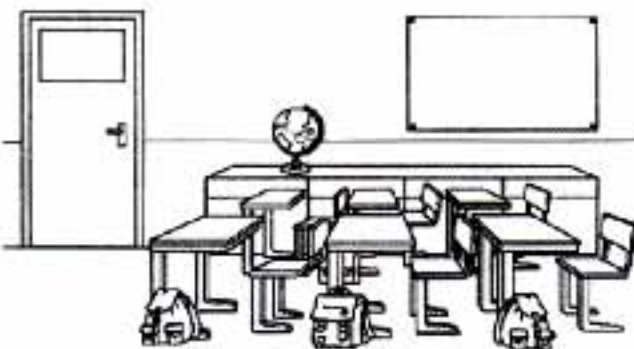

People who help us (connect with social studies)

Lesson 6

Objectives SB P. (30 – 31) / AB P. (28 – 29)

- ◆ To identify vocabulary for people who helps us.
- ◆ To differentiate different kinds of jobs.

People who help us



A teacher helps me write.



A librarian helps me find books.



A nurse helps me feel better.



Unit 2

Activities

1 Match.

صل.



teacher



librarian



friend



nurse

2 Look and circle.

1) A (teacher / librarian) helps me write.



2) A (teacher / nurse) helps me feel better.



3) A (nurse / librarian) helps me find books.



4) A (friend / teacher) helps me with my pen.



3 Look and match.

أنظر و وصل.



A teacher



feel better



A librarian

helps me



write



A nurse



find books

4 Look and put a (✓) or (x).

أنظر و ضع علامة (✓) أو (x).



Unit 2

Writing corner



pencil



pen

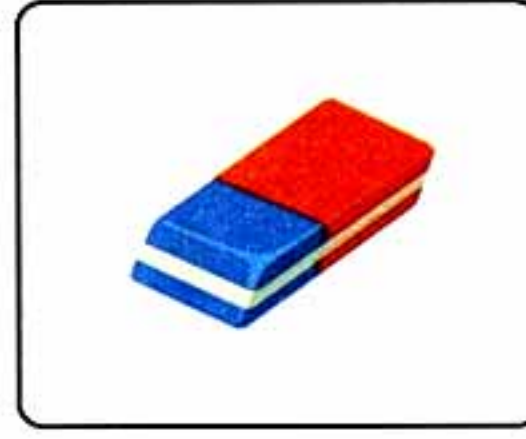

eraser



sharpener

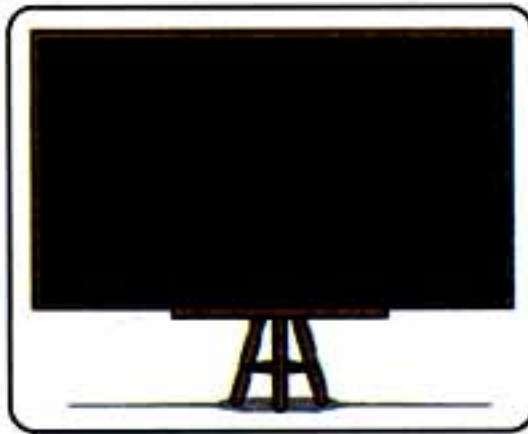

board



chair



table



mouth



one



two

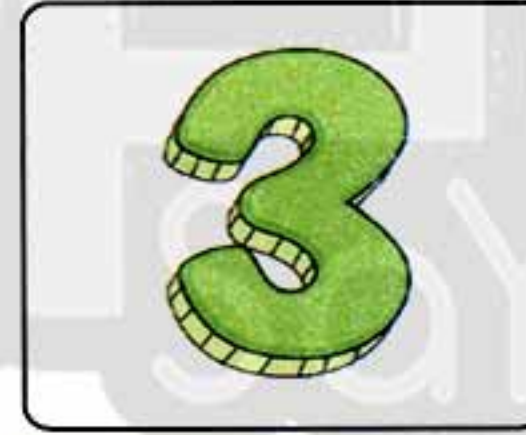

three

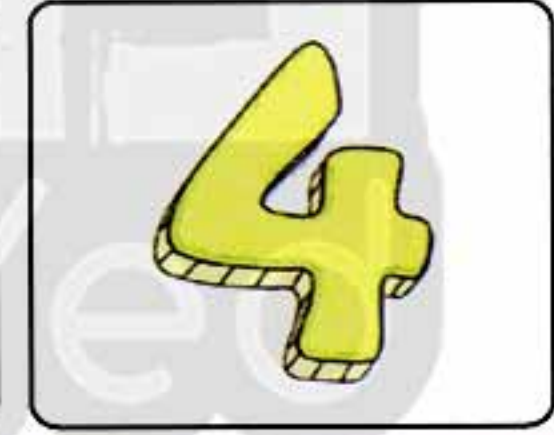

four

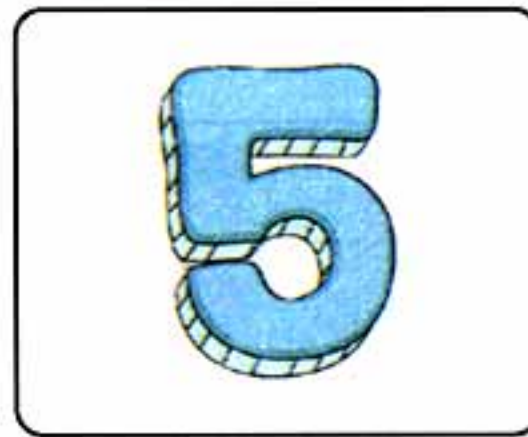

five

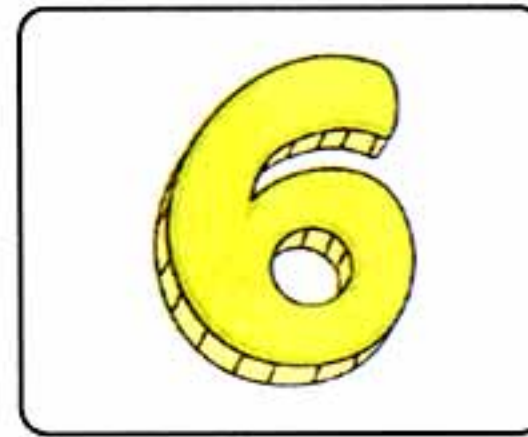

six

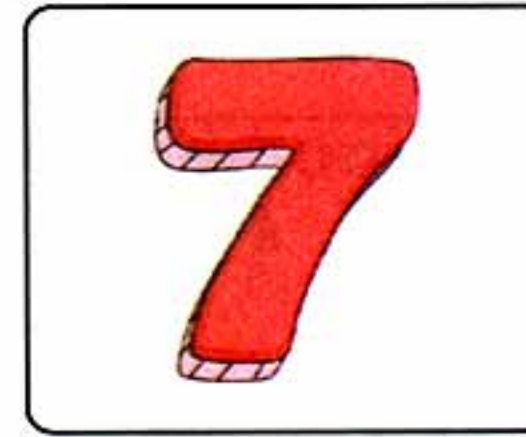

seven

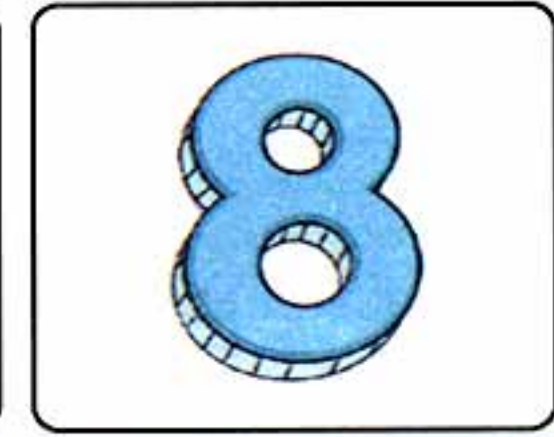

eight

9

nine

10

ten

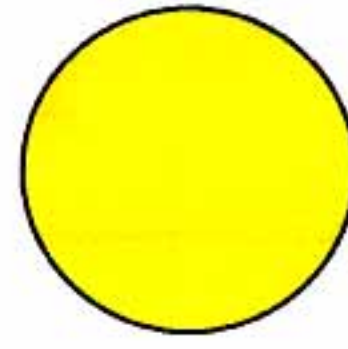

circle



rectangle



square



triangle



teacher



librarian



nurse

اكتب ذاكرولي في البحث وانضم لجروبات ذاكرولي
مع رياض الاطفال للصف الثالث الاعدادي

3

Our animals



◆ Scope of unit 3

Vocabulary

- ◆ rabbit , camel , cat , fish , frog , horse , sheep.
- ◆ land , water.
- ◆ baby , child , teenager , adult.
- ◆ living , non-living , grow , breathe.

Language

- ◆ My favourite animal is the (cat).
- ◆ (Camels) live on land.
- ◆ Living things (eat).
- ◆ Non-living things don't (eat).

Phonics

- ◆ / p / : pen , panda , playground , pyramids.
- ◆ / r / : red , rabbit , Reem , sharpener.

Values

- ◆ Caring for animals.

Integrated cross-curriculum topics

- ◆ Science : Stages of life / frogs.
- ◆ Art : make a collage.
- ◆ Geography : Land and water.

Lesson 1

Vocabulary

Objectives SB P. (40 – 41) / AB P. (38 – 39)

- To identify vocabulary for animals in a picture.

– التعرف على اسماء الحيوانات

Animals



camel جمل



horse حصان



fish سمكة



sheep خروف



rabbit أرنب



frog ضفدع



cat قطة

Unit 3

Activities

1 Look and number.

أنظروا وأكتبوا الرقم.

1) sheep •

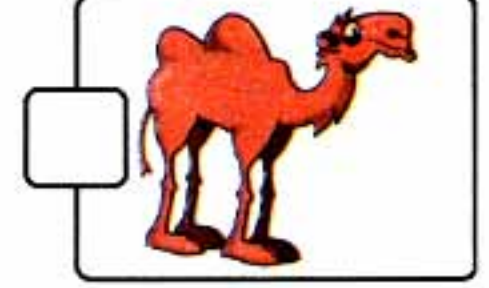

2) cat •

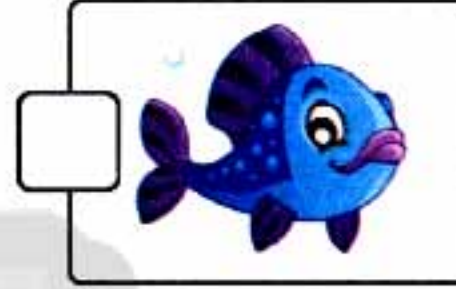

3) rabbit •

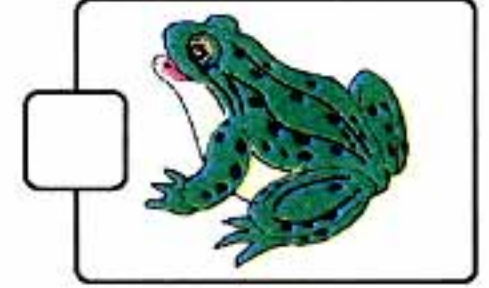

4) camel •

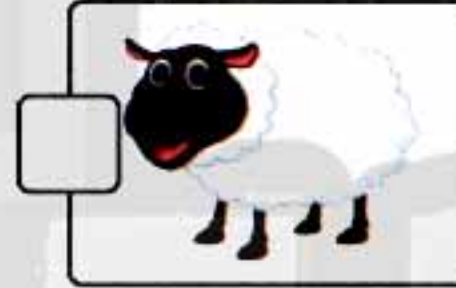

5) horse •

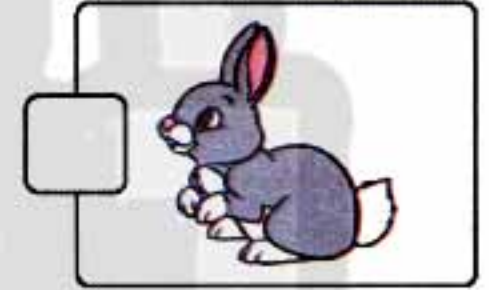

6) frog •

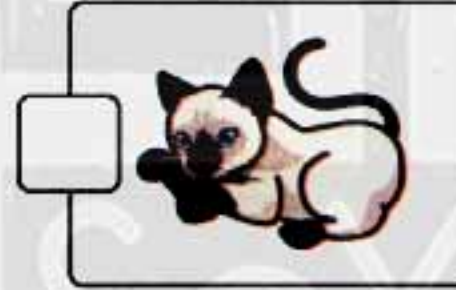

7) fish •



2 Look and circle.

أنظروا وضع دائرة حول الإجابة الصحيحة.

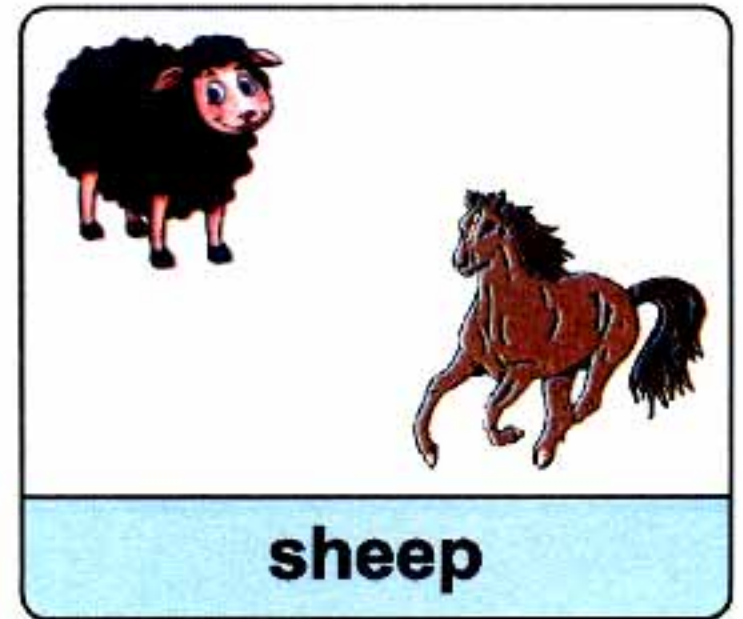
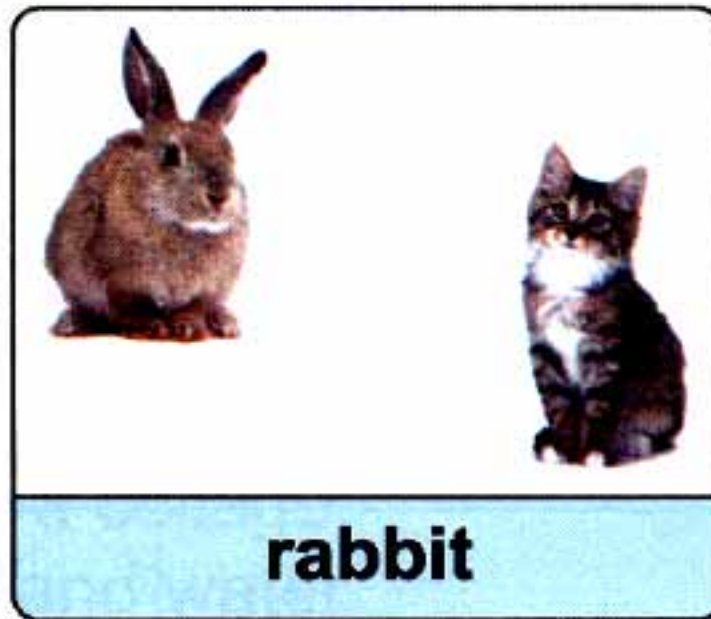
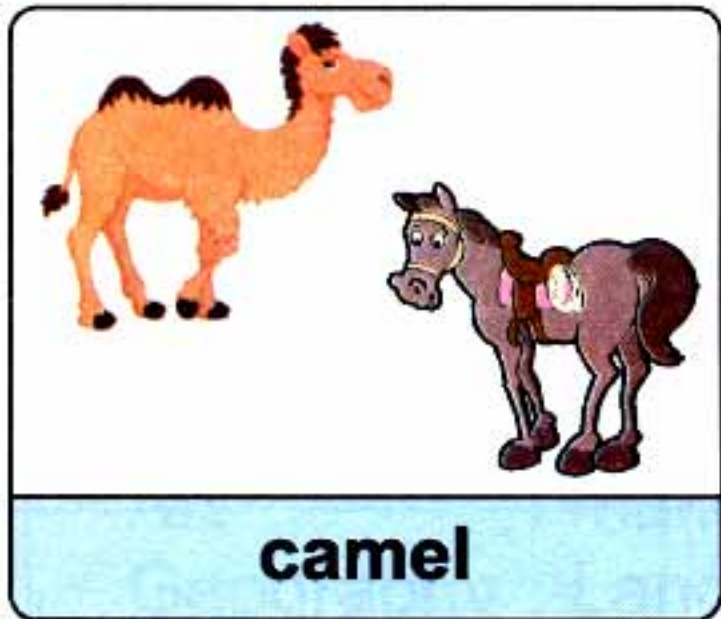



frog



fish



cat

3 Trace and color.

تتبع النقط و لون.

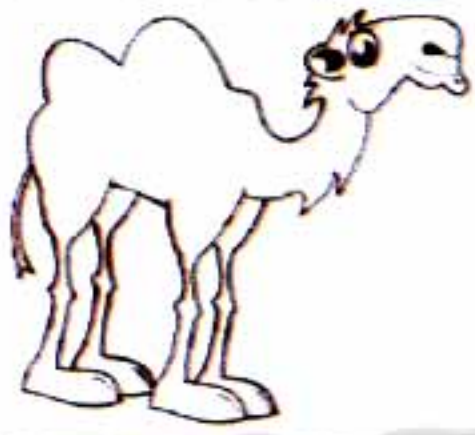

camel

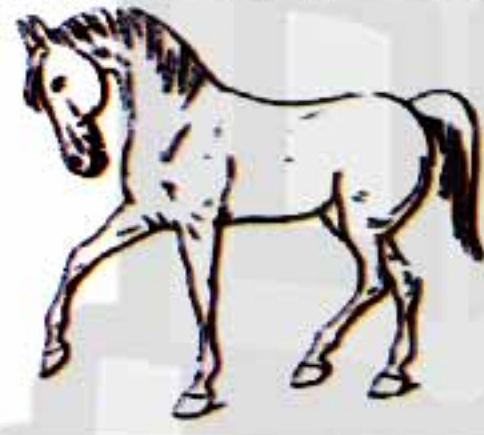

horse

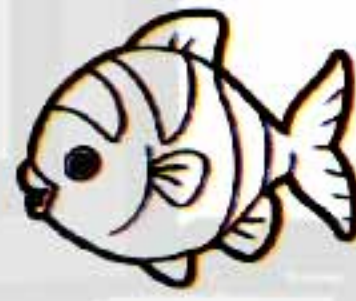

fish

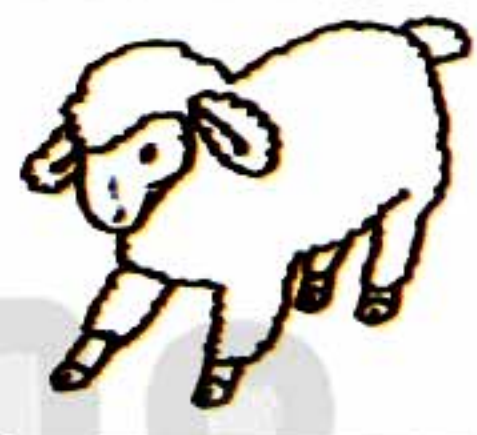

sheep



frog



rabbit



cat



تابع جديد زاكروولي على موقعنا
<https://www.zakrooly.com>

Lesson 2

Where do camels live?
Land and water

Objectives SB P. (42 – 43) / AB P. (40 – 41)

- ♦ To talk about animals. - للتحدث عن الحيوانات.
- ♦ To differentiate between animals that live on land and in water. - للتعرف على الحيوانات التي تعيش في الأرض و في الماء.

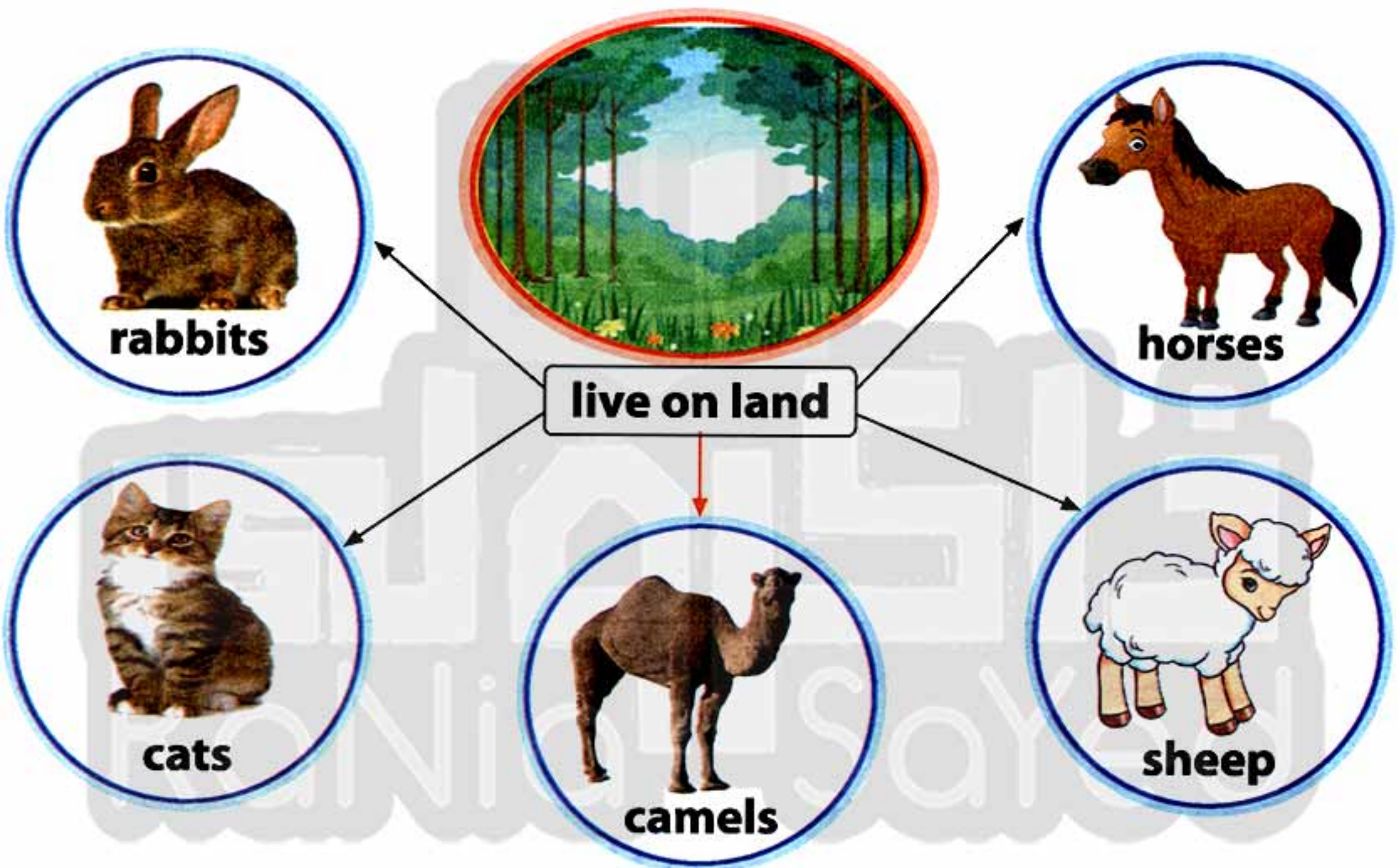

Language Use

◆ Where do live?

- للسؤال عن أين تعيش الحيوانات

Where do camels live?



Camels live **on land.**

Where do fish live?



Fish live **in water.**

Where do cats live?



Cats live **on land.**

Where do frogs live?



Frogs live **in water.**

Where do horses live?

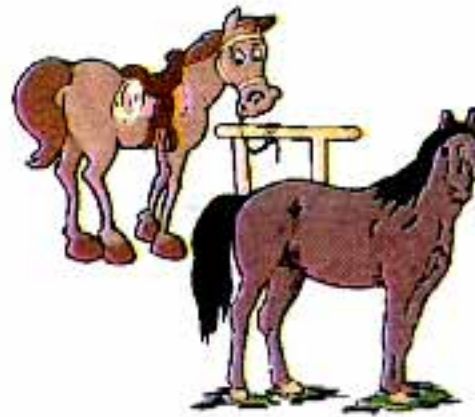

Horses live **on land.**

Unit 3

Activities

1 Match the animals to where it live.

صل الحيوانات بالمكان الذي تعيش فيه.



on land



in water

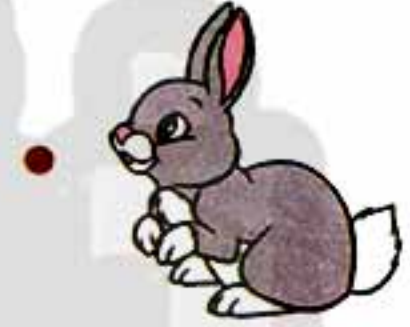

2 Circle and say.

أنظر و ضع دائرة حول الإجابة الصحيحة.



land / water

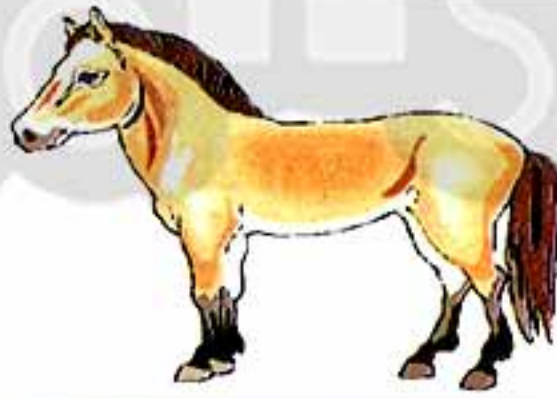

land / water



land / water



land / water



land / water



land / water

3 Color animals that live **on land**. لون الحيوانات التي تعيش في الأرض.

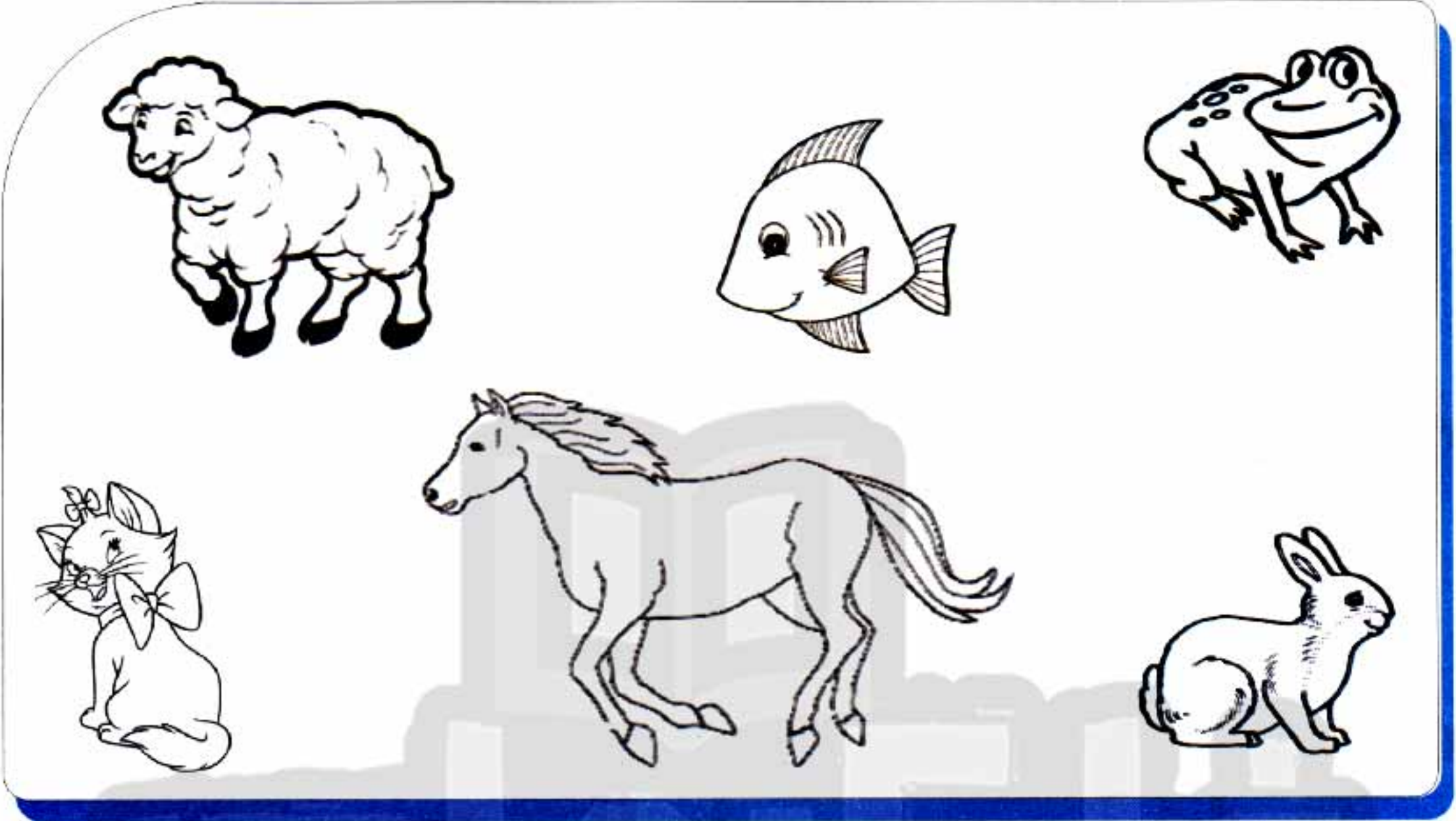

4 Color animals that live **in water**. لون الحيوانات التي تعيش في الماء.



Unit 3

5 Look and tick (✓) the right answer. أنظرو وضع علامة (✓).

Where do frogs live?



- On land.
 In water.

Where do cats live?



- On land.
 In water.

Where do camels live?



- On land.
 In water.

Where do fish live?



- On land.
 In water.

Where do rabbits live?



- On land.
 In water.

Where do sheep live?



- On land.
 In water.

The living world

(Connect with science)

Lesson 3

Objectives SB P. (44 – 45) / AB P. (42 – 43)

- To identify vocabulary for living things.
- To talk about what living things can do.
- To differentiate between **living** and **non-living** things.

Living things

الأشياء الحية



baby

طفل رضيع



cat

قطعة



horse

حصان



rabbit

أرنب



fish

سمكة

Non-living things

الأشياء غير الحية



pen

قلم جاف



pencil

قلم رصاص



table

طاولة



sharpener

براية



book

كتاب

Unit 3

Language Use

- هناك أشياء يقوم بها الكائن الحي ولا يقوم بها الجماد.

Living things



eat



grow



breathe

Non-living things



don't eat

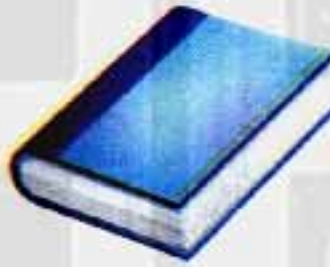

don't grow



don't breathe

اكتب ذاكرولي في البحث وانضم لجدوبات ذاكرولي
مع رياض الاطفال للصف الثالث الاعدادي



تابعنا على صفحتنا على الفيسبوك
www.facebook.com/ZakroolySite



هذا العمل خاص بموقع ذاكرولي التعليمي ولا يسمح بتداوله على مواقع أخرى

Activities

1 Match.

صل.



Living



Non-living



2 Circle the living things.

ضع دائرة على الأشياء الحية.



Unit 3

3 Circle and say.

ضع دائرة حول الإجابة الصحيحة وقل.



eat / don't eat



grow / don't grow



eat / don't eat



breathe / don't breathe



grow / don't grow



breathe / don't breathe

4 Circle the non-living things.

ضع دائرة حول الأشياء الغير حية.



What is your favorite animal?

Lesson 4

Objectives SB P. (46) / AB P. (47)

- To talk about favorite animals. - للتحدث عن حيوانك المفضل.
- To reinforce the value of looking after animals. - للتأكيد على أهمية الإعتناء بالحيوانات

Animals



camel جمل



fish سمكة



horse حصان



sheep خروف



rabbit أرنب



frog ضفدع



panda دب الباندا

Language Use

- What is your favorite animal? - (ما هو حيوانك المفضل؟)
- تستخدم للسؤال عن الحيوان المفضل لدى شخص ما.

What is your favorite animal?



My favorite animal is the panda.

What is your favorite animal?



My favorite animal is the rabbit.

Unit 3

Activities

1 Match.

صل.

1) panda •

2) camel •

3) sheep •

4) frog •

5) horse •

6) rabbit •

7) cat •

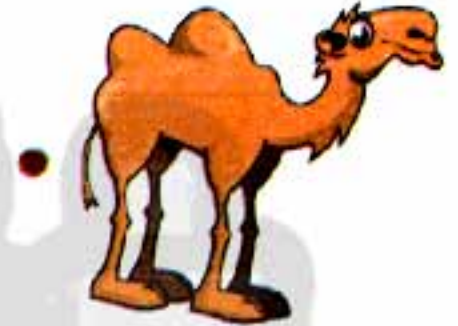

2 Look and circle.

أنظر و ضع دائرة حول الإجابة الصحيحة.

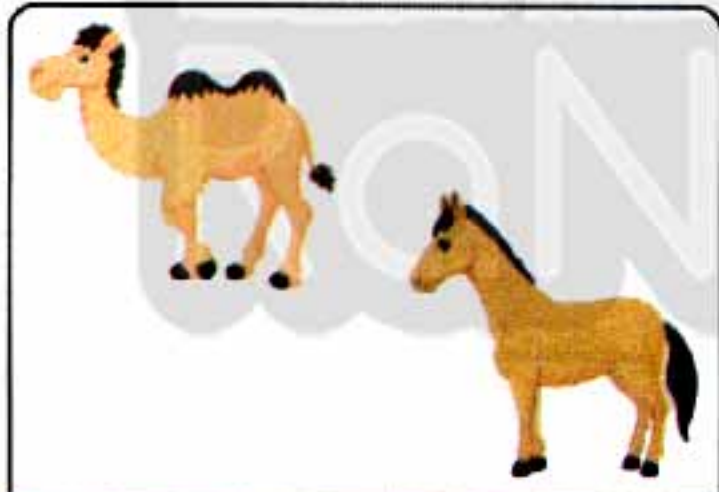

horse

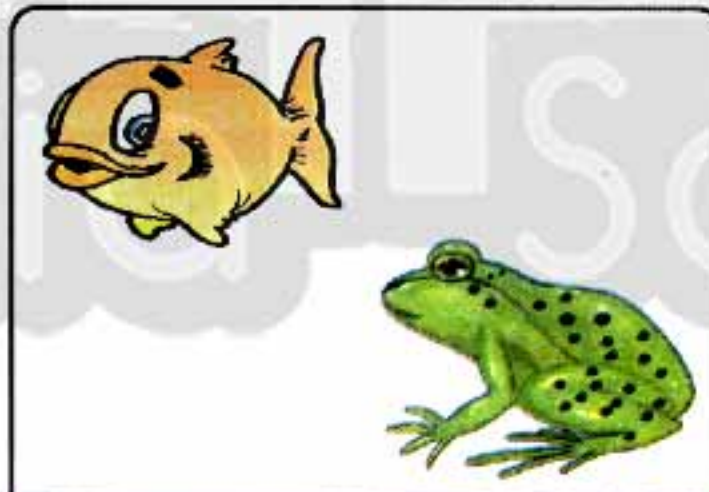

fish



panda

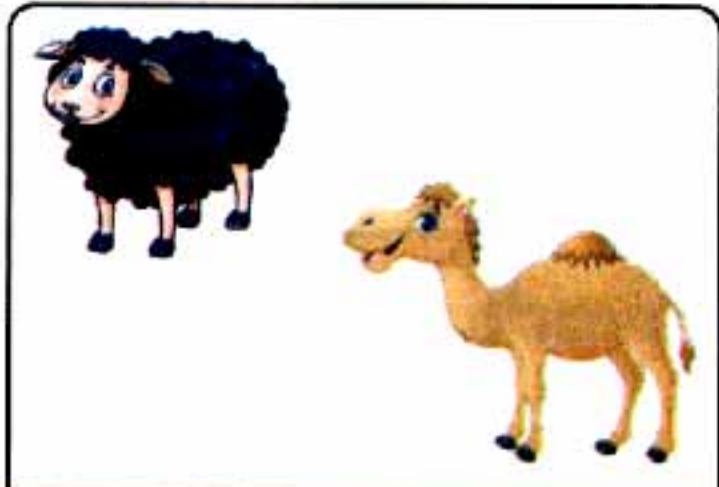

camel

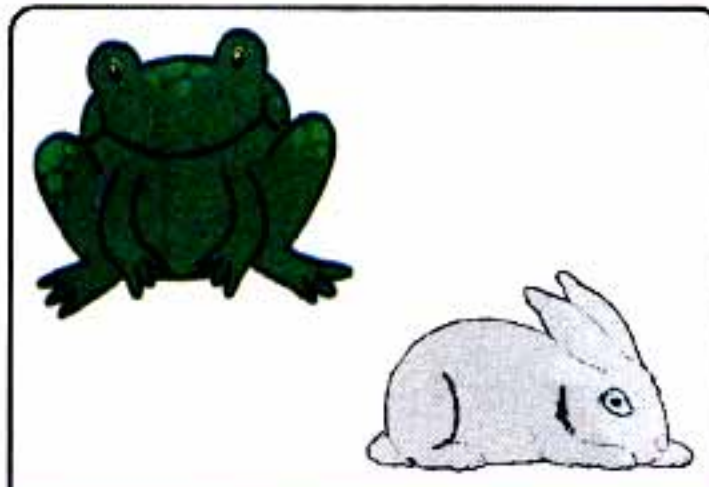

rabbit

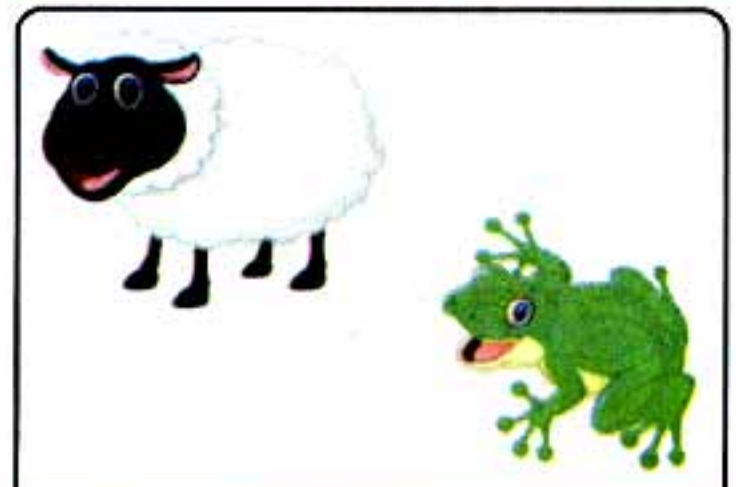

frog

3 Look and tick (✓) the right answer.

أنظر و ضع علامة (✓).

What is your favorite animal?



panda

cat

What is your favorite animal?



horse

camel

What is your favorite animal?



rabbit

fish

What is your favorite animal?



sheep

frog

4 Color your favorite animal.

لون حيوانك المفضل.

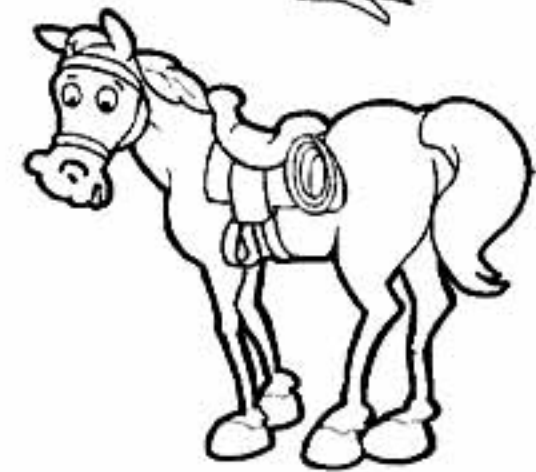
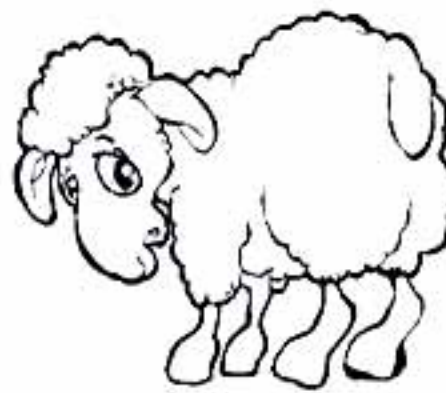
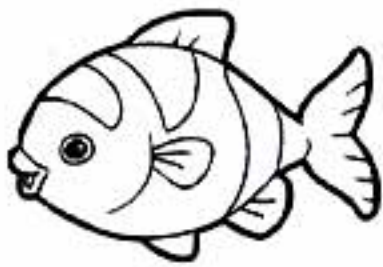

Lesson 6

Phonics

P p

Trace

P P P P P P P P

p p p p p p p p

Write

1
2
P

P

1
2
p

p

Find P / p

O	b	P	k	O	B
d	p	w	u	P	R
p	u	B	O	A	P

Color

Playground

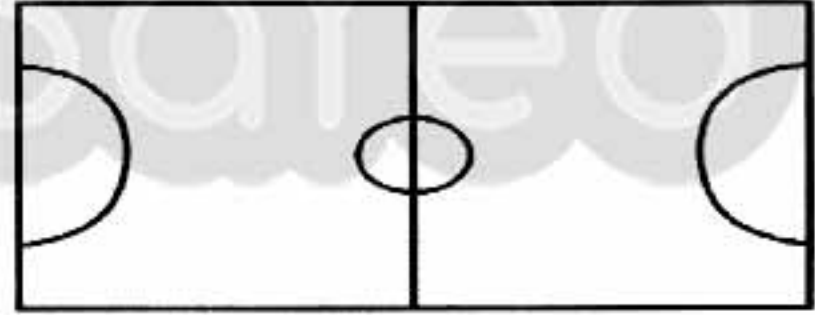

Words



panda

دب الباندا



pan

طاسة



pyramids

أهرامات

R r

Trace

R R R R R R R R R R

r r r r r r r r r r

Write



R



r

Find R / r

R b N k n r
d n R v r Q
u r s n R N

Color

Ring



Words



rabbit

أرنب



red

أحمر



Reem

ريم

Unit 3

Activities

1 Match.

صل.

1) panda

2) pyramids

3) playground

4) red

5) rabbit

6) Reem

7) ring

8) pan



2 Look and circle.

أنظر و ضع دائرة حول الإجابة الصحيحة.

1



p / r abbit

2



p / r anda

3



P / R eem

4



p / r ed

5

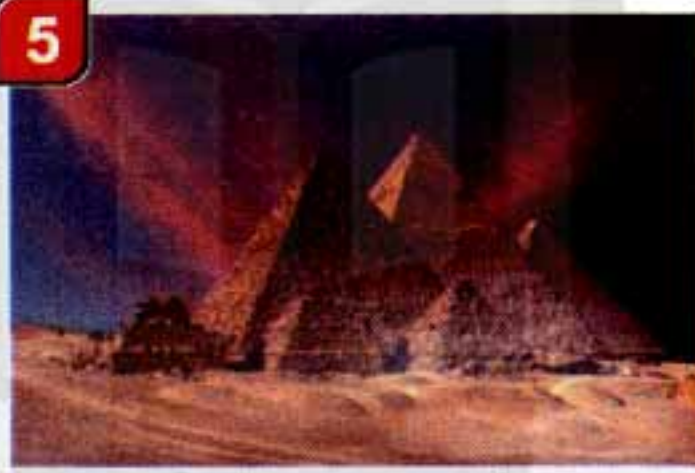

p / r yramids

6

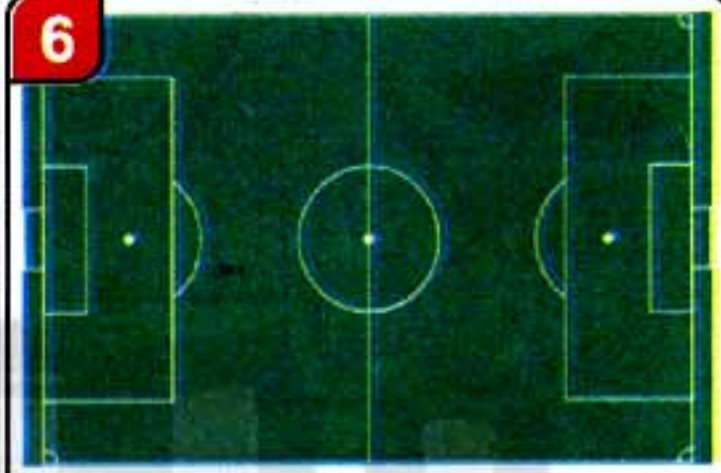

p / r layground

3 Put / p / or / r /.

ضع (p) أو (r).

1



- anda

2



- abbit

3



- ed

4



- yramids

5

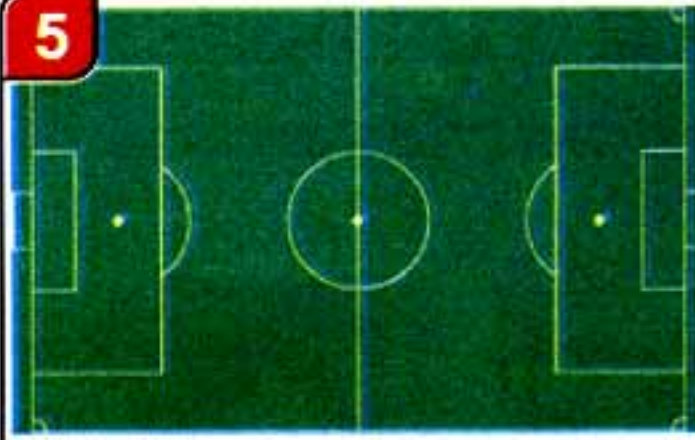

- layground

6



sharpe -

Unit 3

4 Color words that have /p/.

لون الكلمات التي بها حرف (p)

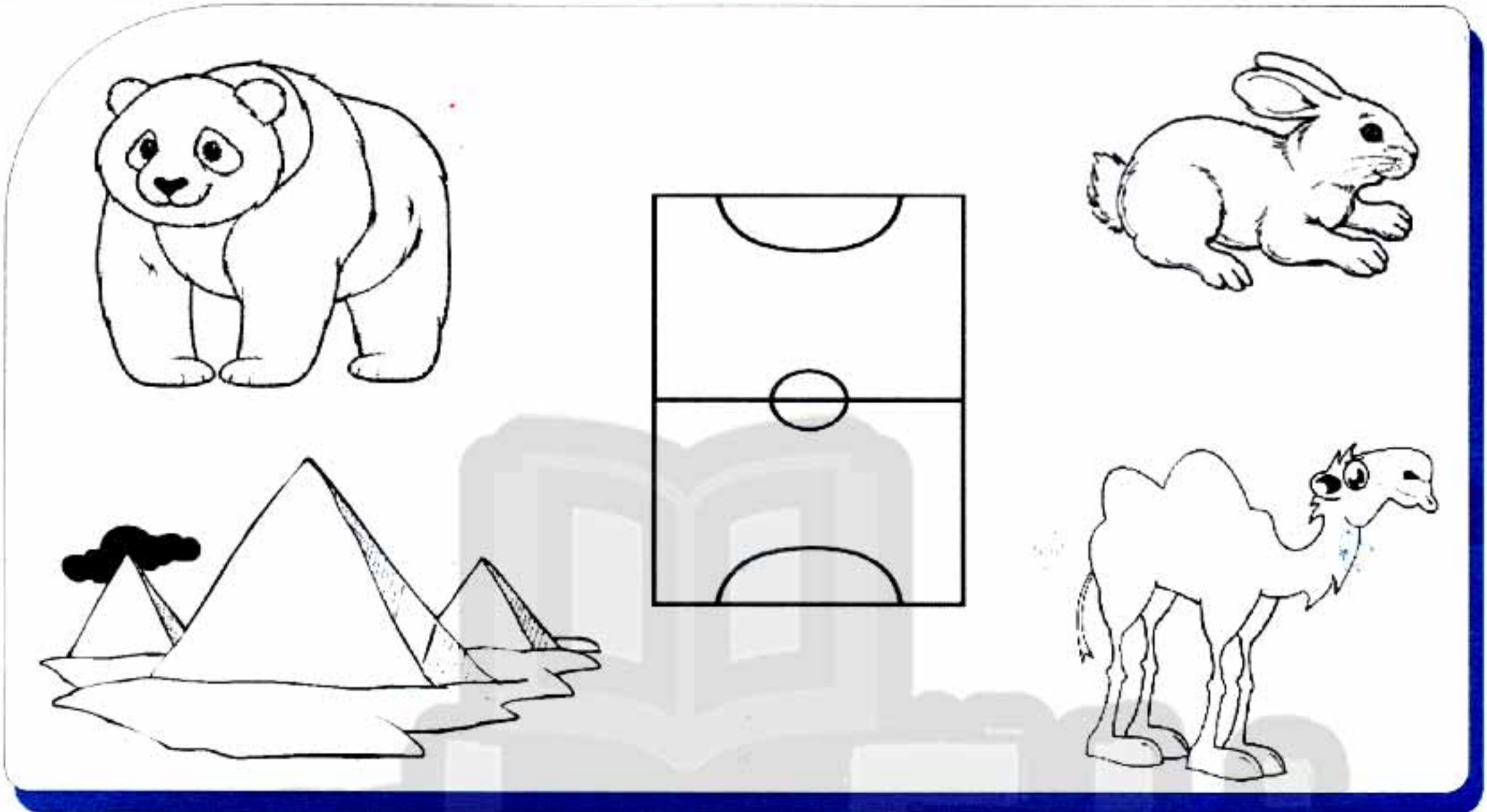

5 Trace.

تابع جديد زاكروولي على موقعنا
<https://www.zakrooly.com>

تتبع.



panda

panda



red

red



pyramids

pyramids



rabbit

rabbit

Growing up

(Connect with science)

Lesson 6

Objectives SB P. (50 – 51) / AB P. (48 – 49)

- ♦ To recognize stages of human's life. - دورة حياة الانسان.
- ♦ To recognize stages of frog's life cycle. - دوره حياة الضفدع.

Stages of life

Human



Frogs

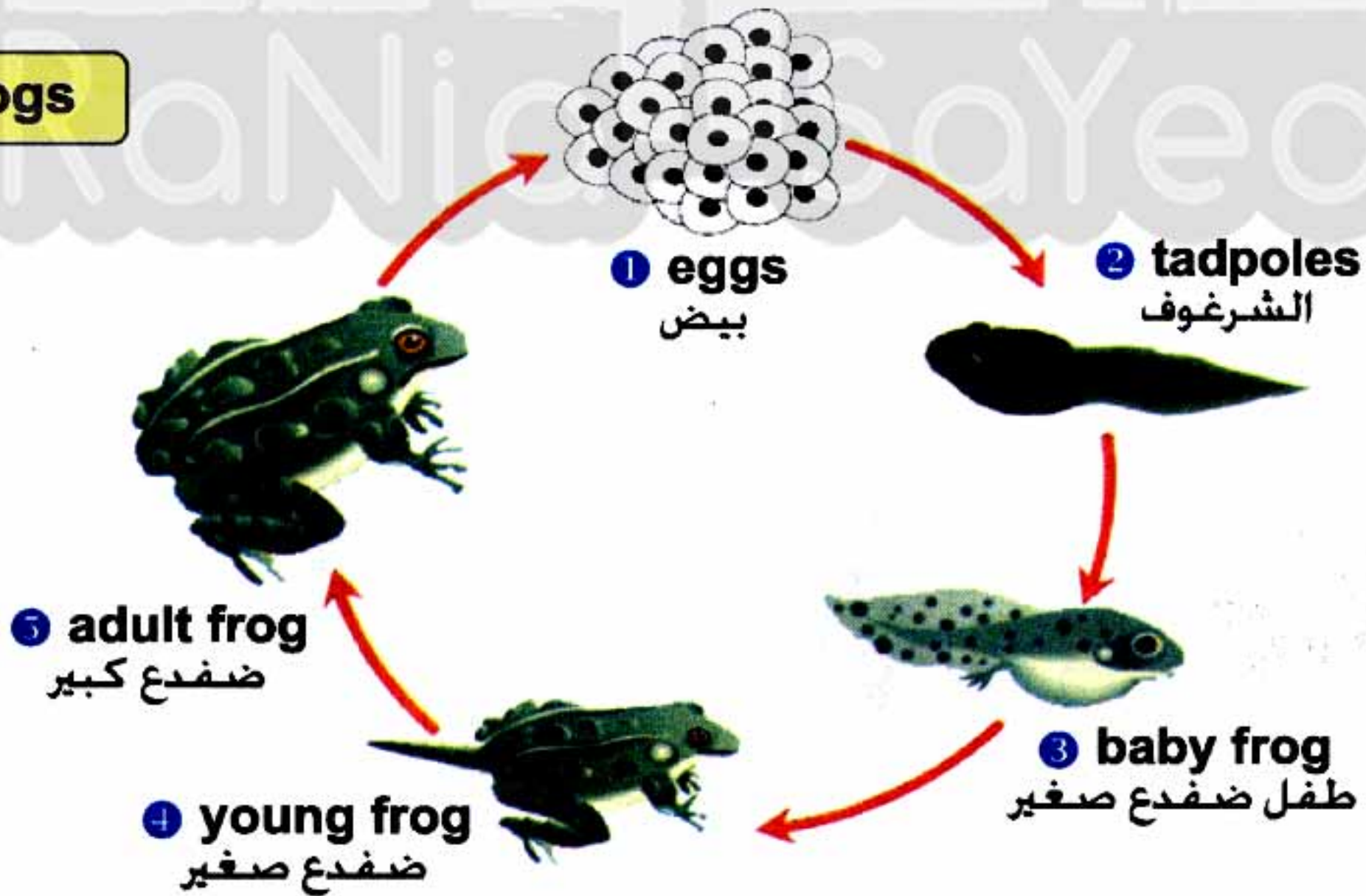

Unit 3

Activities

1 Match.

صل.

1) baby •



2) child •



3) teenager •



4) adult •



2 Look and circle.

أنظر و ضع دائرة حول الإجابة الصحيحة.



baby



child



adult



adult frog



baby frog



teenager

3 Order and write the number.

رتب و اكتب الرقم.



1

baby



child



adult



teenager

4 Order and write the number.

رتب و اكتب الرقم.

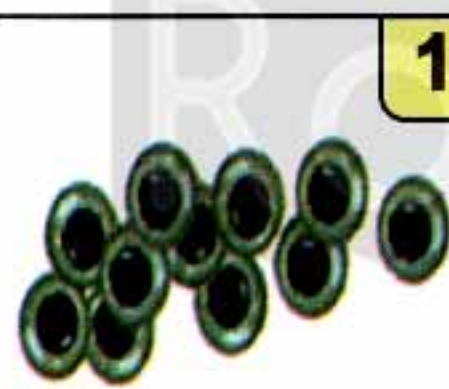

1

eggs



tadpoles



adult frog



baby frog

اكتب ذاكرولي في البحث وانضم لجدوبات ذاكرولي
مع رياض الاطفال للصف الثالث الاعدادي

Unit 3

Writing Corner



rabbit



camel



cat



fish



panda

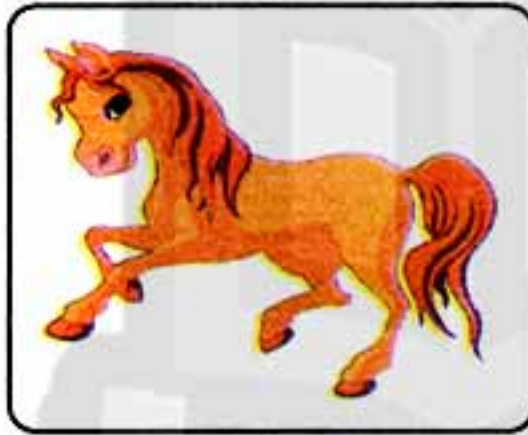

horse



frog



sheep



baby



child



teenager



adult



eat



grow



breathe

Our world



◆ Scope of unit 4

Vocabulary

- ◆ salad , tomato , cucumber , lettuce , carrot , corn.
- ◆ cloud , rain , puddle , sea , river.
- ◆ gray , black , white.
- ◆ summer , winter.

Language

- ◆ It's good / bad for you.
- ◆ Let's wash our (hands).
- ◆ I like / don't like (rain).

Phonics

- ◆ / d / : **d**addy , **d**uck , **h**and , salad , **D**ina.
- ◆ / s / : **s**ister , **s**un , **s**alad , **S**eleem.

Values

- ◆ Independence.

Integrated cross-curriculum topics

- ◆ Science : Healthy food.
- ◆ Art : Make a food wheel.

Lesson 1

Vocabulary

Objectives SB P. (58 – 59) / AB P. (54 – 55)

- التعرف على أنواع الطعام.
- To identify vocabulary for food in a picture.
- To reinforce the importance of eating healthy food.
- التأكيد على أهمية تناول طعام صحي

Food طعام



carrot

جزر



tomato

طماطم



cucumber

خيار



lettuce

خس



salad

سلطة



corn

ذرة

لا تنس الاشتراك في
قنوات ذاكرولي
على تطبيق التليجرام

تابع جديد ذاكرولي على
فيسبوك
تويتر
وانس اب
تليجرام

Activities

1 Match.

صل.

1) corn



2) tomato



3) cucumber

4) lettuce

5) salad



6) carrot

2 Look and circle.

أنظر و ضع دائرة حول الإجابة الصحيحة.

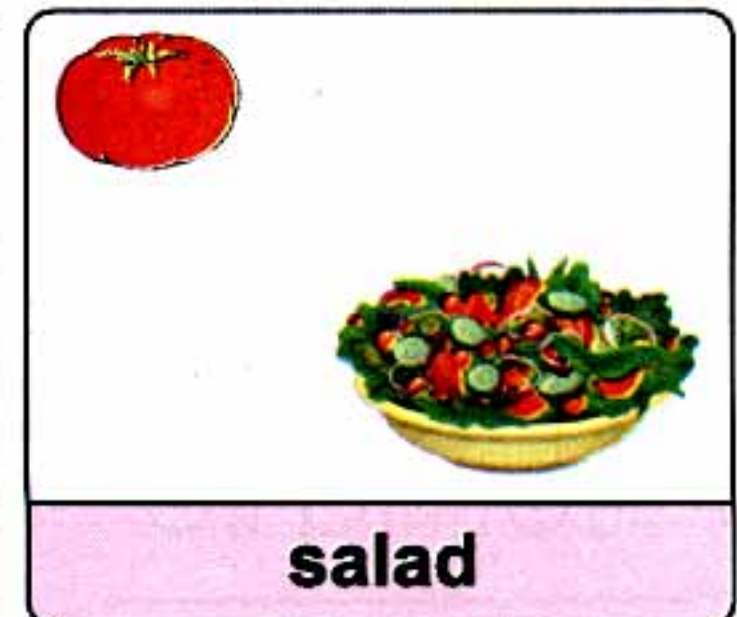
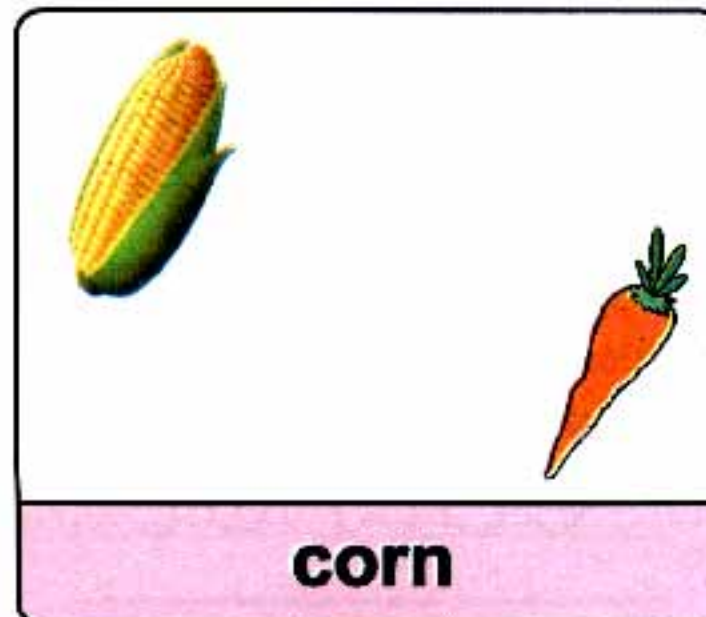
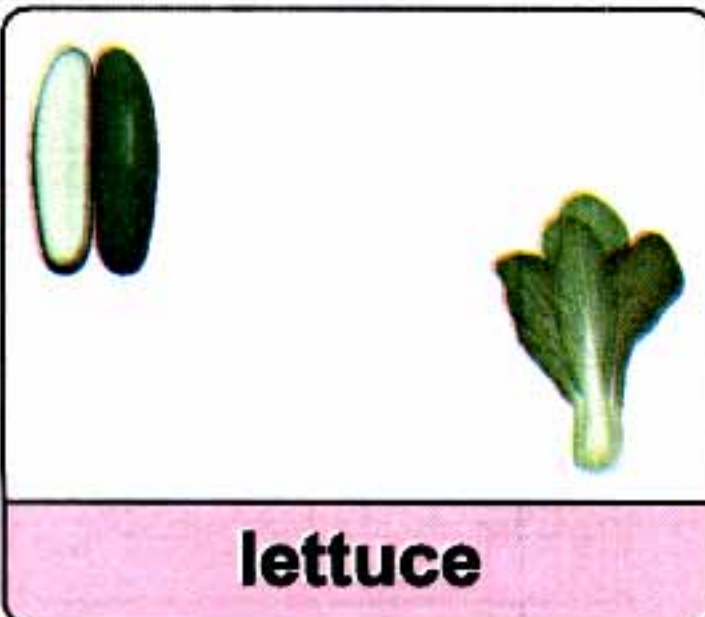
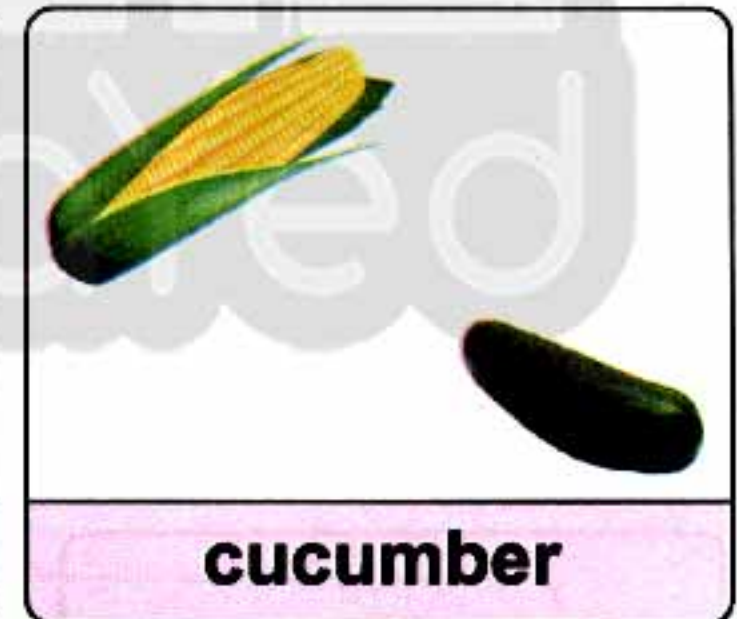
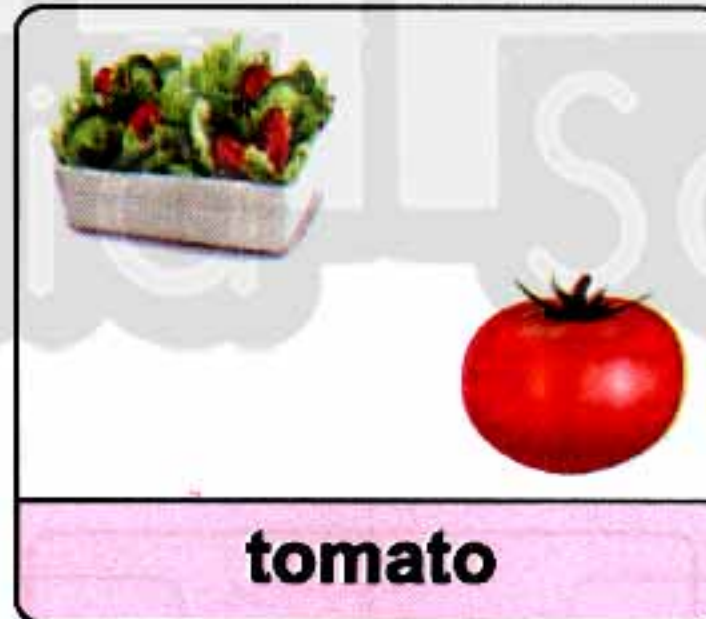
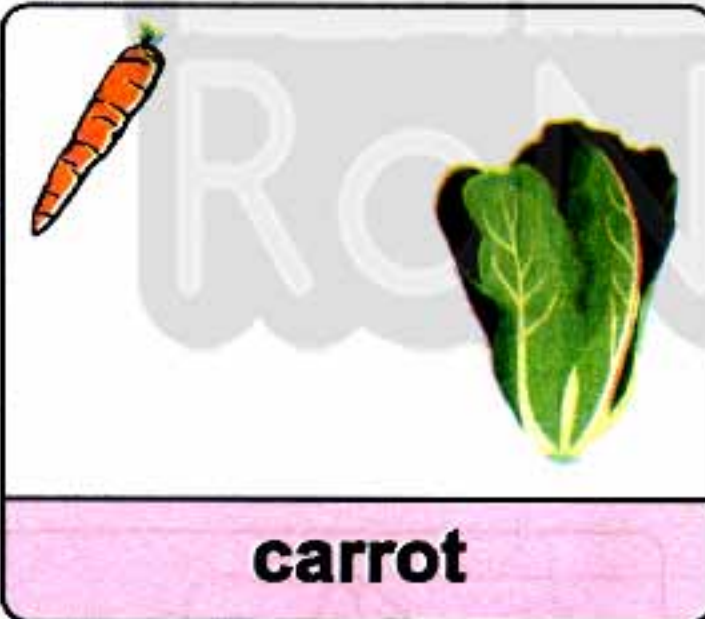

Unit 4

3 Look and tick (✓).

أنظر و ضع علامة (✓).

1) I can see a carrot.



Yes

No

2) I can see a tomato.



3) I can see a cucumber.



4) I can see salad.



5) I can see a lettuce.



6) I can see a corn.



4 Trace and color.

تتبع النقط و لون.



corn



salad

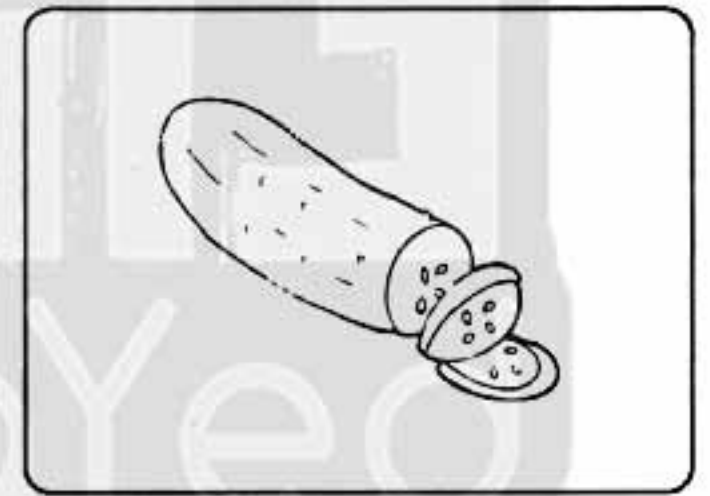

cucumber

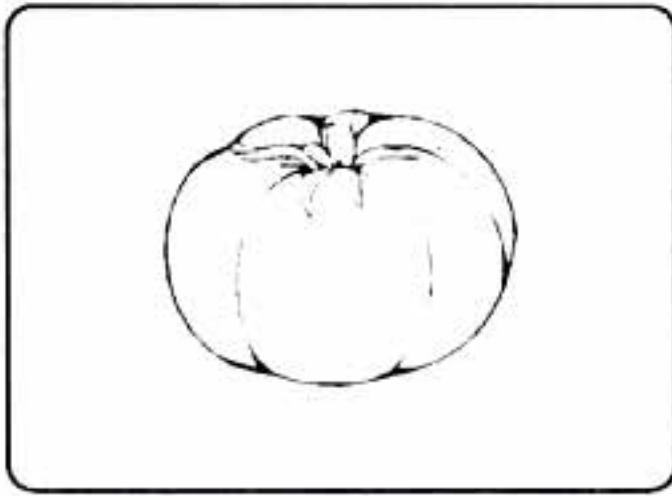

tomato

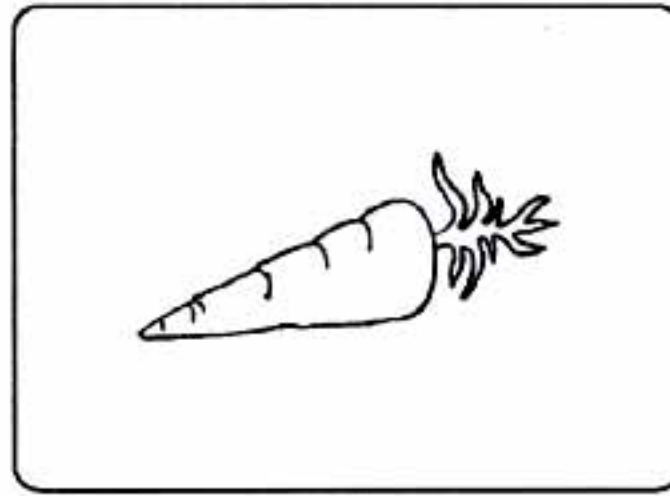

carrot



lettuce

Healthy or unhealthy?

Lesson 2

Objectives SB P. (60) / AB P. (56)

- To differentiate between healthy and unhealthy food.

- للتفرقة بين الطعام الصحي والغير صحي.

Healthy food

✓



طعام صحي



cucumber

خيار



tomato

طماطم



water

ماء

Unhealthy food

x



طعام غير صحي



sweets

حلوى



cola

كولا

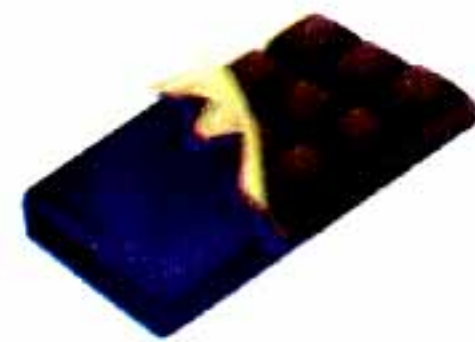

chocolate

شيكولاته

Unit 4

Activities

1 Look and tick (✓).

أنظرو وضع علامة (✓).

1) It is healthy.



Yes

No

2) It is unhealthy.



3) It is healthy.



4) It is unhealthy.



5) It is healthy.

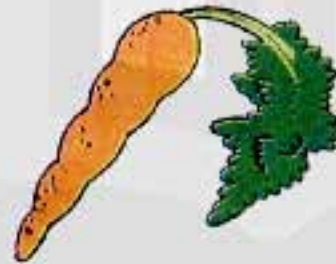

6) It is unhealthy.



2 Look and draw 😊 or ☹️.

أنظرو وأرسمم 😊 أو ☹️.

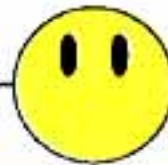
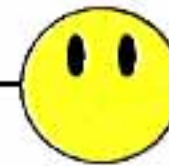

3 Look and circle.

أنظر و ضع دائرة حول الإجابة الصحيحة.



healthy / unhealthy



healthy / unhealthy



healthy / unhealthy



healthy / unhealthy



healthy / unhealthy



healthy / unhealthy



healthy / unhealthy

لا تنس الاشتراك في
قنوات ذاكرولي
على تطبيق التليجرام



healthy / unhealthy

4 Color healthy food.

لون الطعام الصحي.

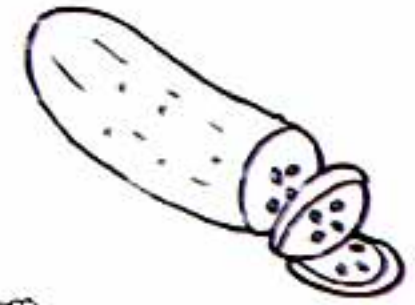
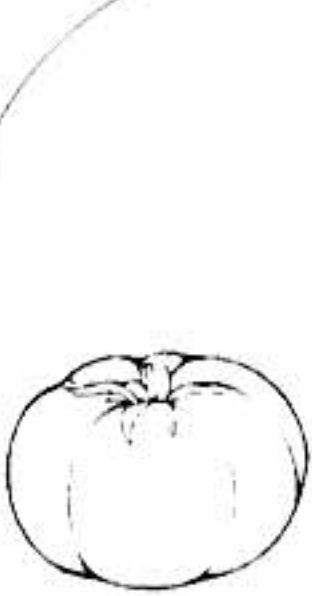

Lesson 3

Let's wash our hands!

Objectives SB P. (61) / AB P. (57)

- ◆ To follow the instructions of washing our hands. تعليمات غسل اليدين
- ◆ To reinforce the value of cleanliness. أهمية النظافة



eat يأكل



touch يلمس



cough كحة



wash يغسل

Let's wash our hands!

Before قبل



We eat.



We touch a baby.

After بعد



We use the bathroom.



We touch animals.



We cough.

Activities

1 Look and tick (✓).

أنظر و ضع علامة (✓).

We wash our hands Before

نحن نغسل أيدينا قبل.

We use the bathroom.
()We eat.
()We touch a baby.
()

We wash our hands After

نحن نغسل أيدينا بعد.

We cough.
()We eat.
()We touch animals.
()

2 Trace.

تتبع.

I wash my hands

تابع جديد زاكروولي على موقعنا
<https://www.zakrooly.com>

Lesson 4

Is it water?
(Connect with science)

Objectives SB P. (62 – 63) / AB P. (58 – 59)

- ◆ To talk about ways to see water. - أين نرى الماء.
- ◆ To reinforce the importance of water in our life. - أهمية الماء في حياتنا.
- ◆ To reinforce the importance of rain and the sun for plants. - أهمية المطر و الشمس للنبات.

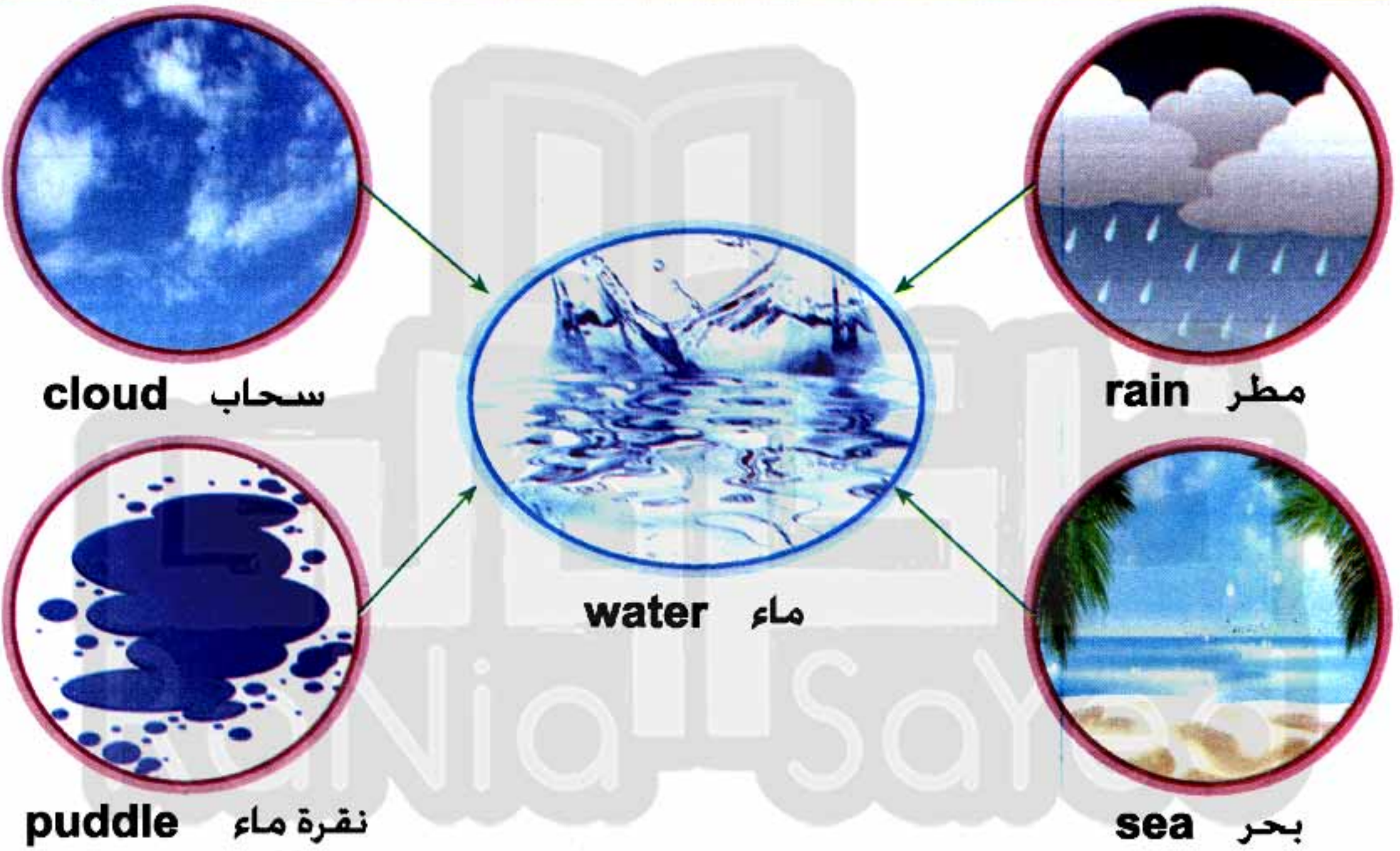

Note

- ◆ The **sun** and **rain** are good for (corn). الشمس والمطر مهم للذرة.



Activities

1 Match.

صل.

1) The sun •



2) rain •



3) cloud •



4) sea •

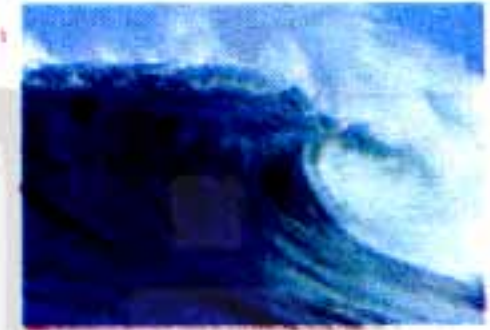

5) puddle •



6) water •

2 Look and circle.

أنظر و ضع دائرة حول الإجابة الصحيحة.



The sun



rain



puddle

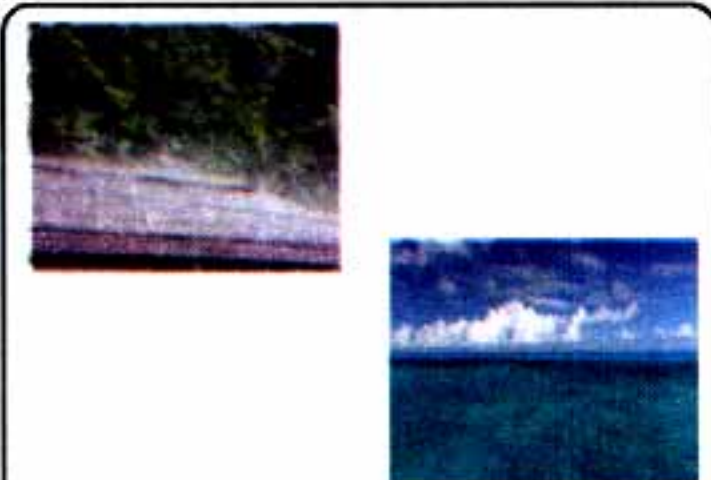

sea



cloud



water

Lesson 5

Living or Non-living?

Objectives SB P. (64) / AB P. (60)

- ◆ To use vocabulary for living and non-living things.
- ◆ To differentiate between living and non-living things.

Living الأشياء الحية	Non-living الأشياء غير الحية
	
fish سمكة	can علبه كانز
	
frog ضفدع	bottle زجاجة
	
duck بطة	plastic bag كيس بلاستيك

Note

- ◆ One syllable. هناك كلمات تتكون من مقطع واحد ويراعى هذا عند النطق.
(fish – frog – duck)
- ◆ Two syllable. هناك كلمات ذات مقطعين ويراعى هذا عند النطق.
(river – bottle – water)

Activities

1 Match.

صل.

1) duck •



2) frog •

3) river •

4) fish •

5) bottle •

6) water •



2 Look and circle.

أنظر و ضع دائرة حول الإجابة الصحيحة.



frog



bottle



water

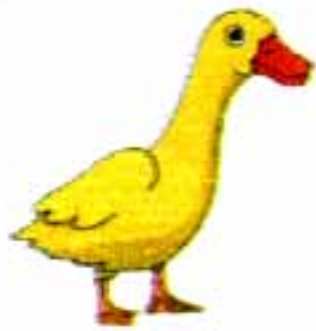

duck



fish



river

Unit 4

3 Look and circle.

أنظر و ضع دائرة حول الإجابة الصحيحة.



Living / Non-living

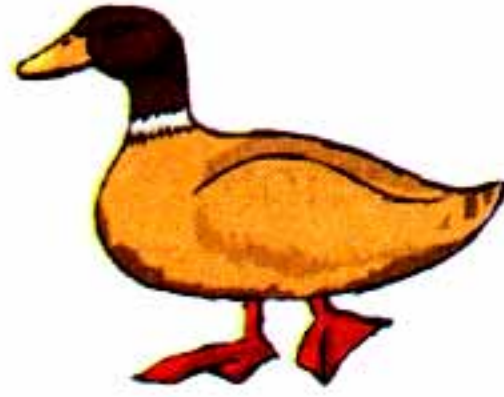

Living / Non-living



Living / Non-living



Living / Non-living



Living / Non-living



Living / Non-living

4 Color living things.

لون الأشياء الحية.

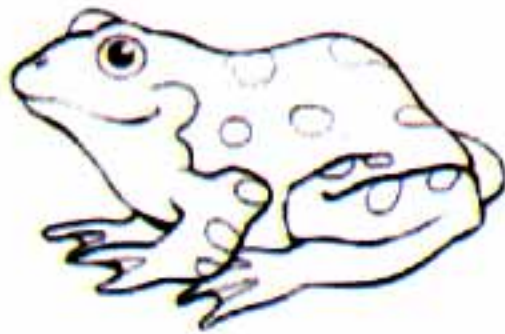









نقومه في أي عمل عليه العلامة ري

Lesson 6

Sorting

Objectives SB P. (65) / AB P. (61)

- ◆ To revise vocabulary learnt before.
- ◆ To sort vocabulary.

Colors ألوان	Animals حيوانات	Food طعام
 red أحمر	 cat قطة	 apple تفاحة
 yellow أصفر	 cow بقرة	 cake كيكة
 green أخضر	 horse حصان	 corn ذرة

تفوقه في أي عمل عليه العلامة دي

Unit 4

Activities

1 Match.

صل.

1) red •



2) yellow •



3) apple •

4) cake •



5) cat •



6) cow •

2 Look and tick (✓).

أنظر و ضع علامة (✓).

Colors



yellow ()



cat ()



red ()

Animals

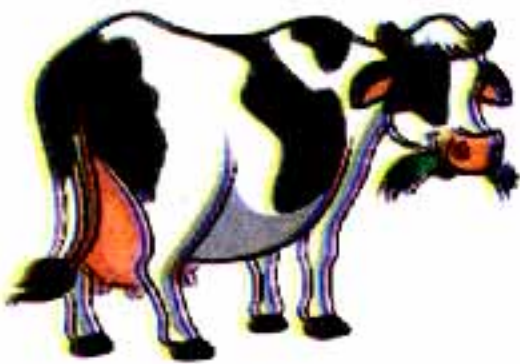

cow ()

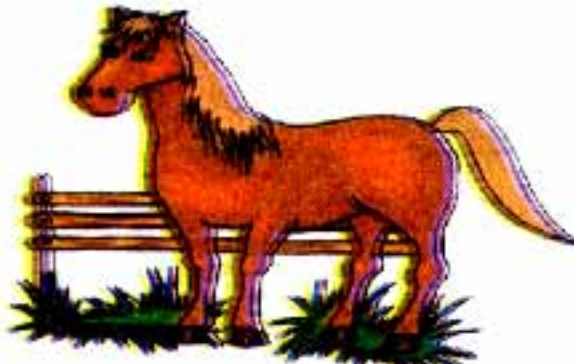

horse ()



apple ()

3 Color animals.

لون الحيوانات.

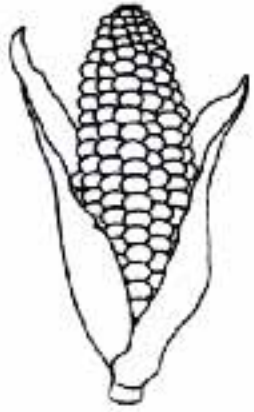
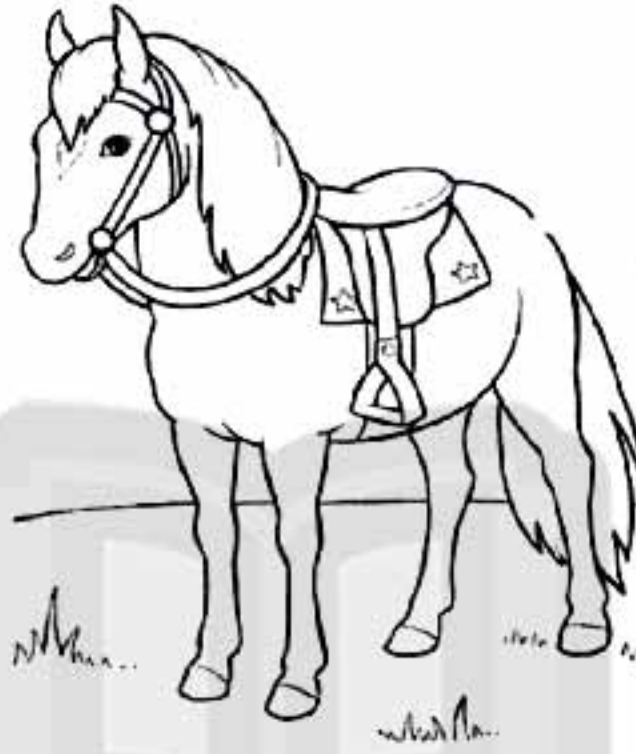

4 Color food.

لون الطعام.

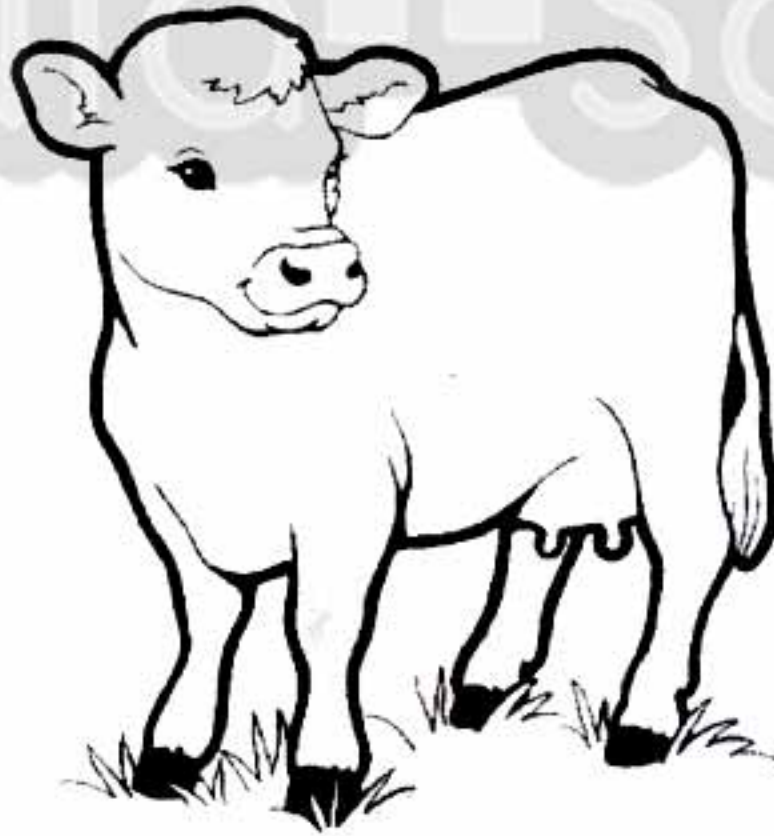

Lesson 7

Phonics

D d

Trace

D D D D D D D D

d d d d d d d d

Write

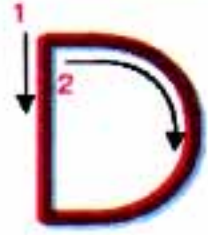

D



d

Find D / d

N b D k m d
 d m w v D R
 S u d m A D

Color



Dog

Words



Dina

دينا



Daddy

أب



duck

بطة

Unit 4

S s

Trace

S S S S S S S S S

s s s s s s s s s

Write

S S

s s

Find S / s

S b N k s R
 d s w v N S
 R u S n A N

Color



Sun

Words



Seleem

سليم



salad

سلطة



sister

أخت

Unit 4

Activities

1 Match.

- 1) daddy •
- 2) duck •
- 3) dog •
- 4) sun •
- 5) sad •
- 6) six •



صل.

2 Circle the letter.

ضع دائرة حول الحرف الصحيح.



d / s uck



d / s og



d / s alad

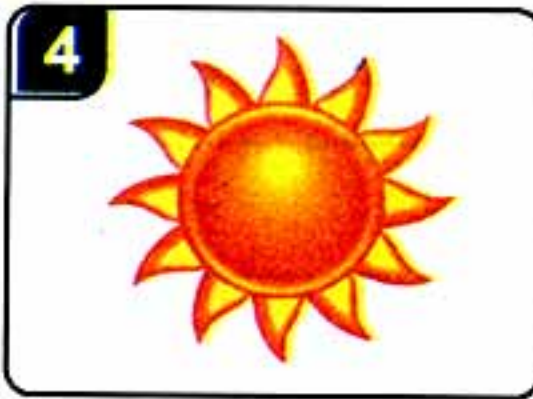

d / s un



d / s addy



d / s ister

3 Put s or d.

ضع s أو d.



- uck



- og



- addy



- alad



- ix



- ister



- un



han -

4 Trace.

تتبع.



duck



dog

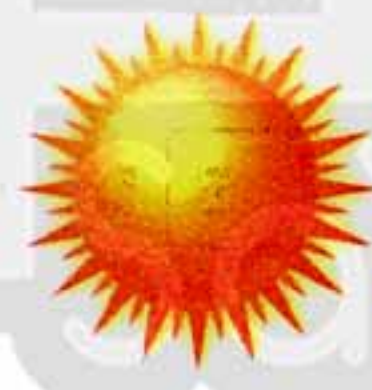

sun



six

duck

dog

sun

six

duck

dog

sun

six

Unit 4

5 Color words that have /d/.

لون الكلمات التي بها حرف / d /.

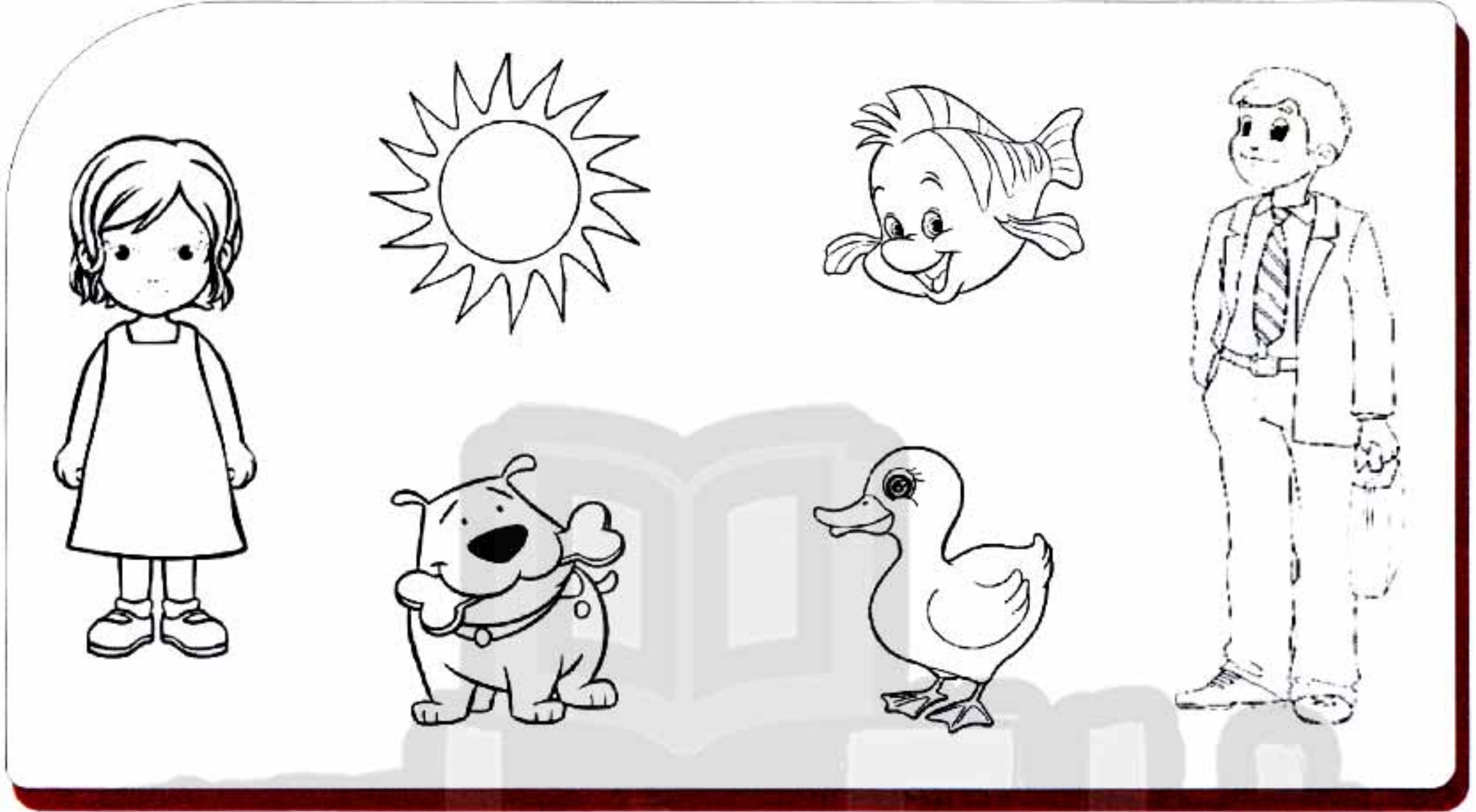

6 Color words that have /s/.

لون الكلمات التي بها حرف / s /.



نقوم في أي عمل عليه العلامة دي

What color is it? (Connect with Art)

Lesson 8

Objectives SB P. (68) / AB P. (64)

- ◆ To revise vocabulary for colors. - للتعرف على الألوان.
- ◆ To ask and answer question "What color is it?" - ما هذا اللون.
- ◆ To use colors to describe things. - استخدام الألوان لوصف الأشياء.

Colors

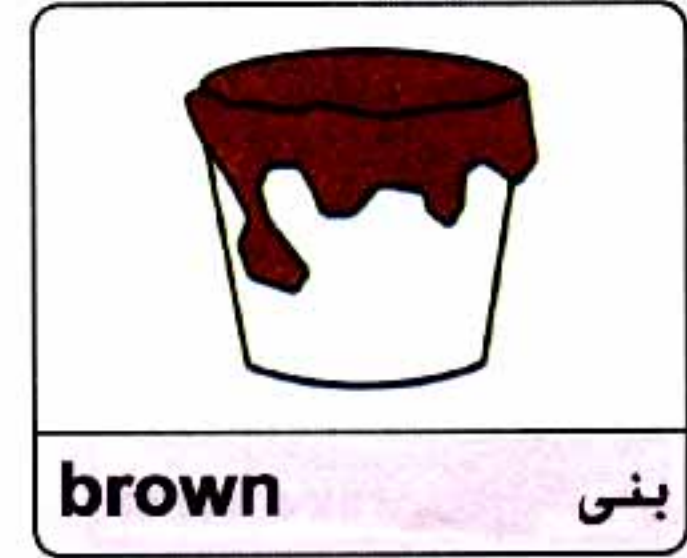
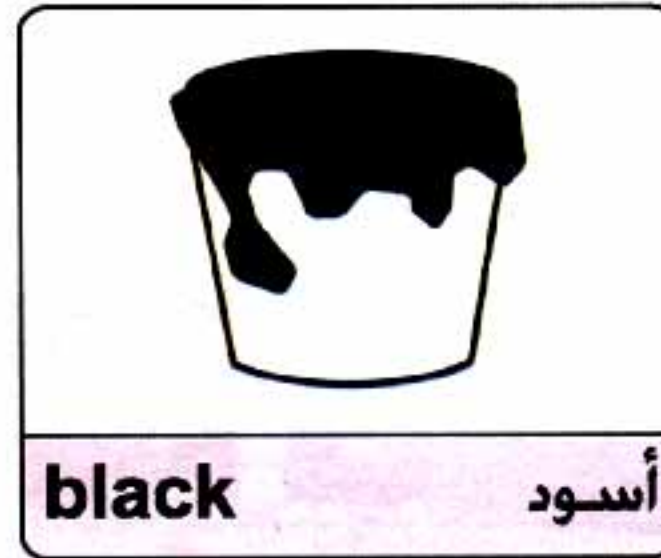
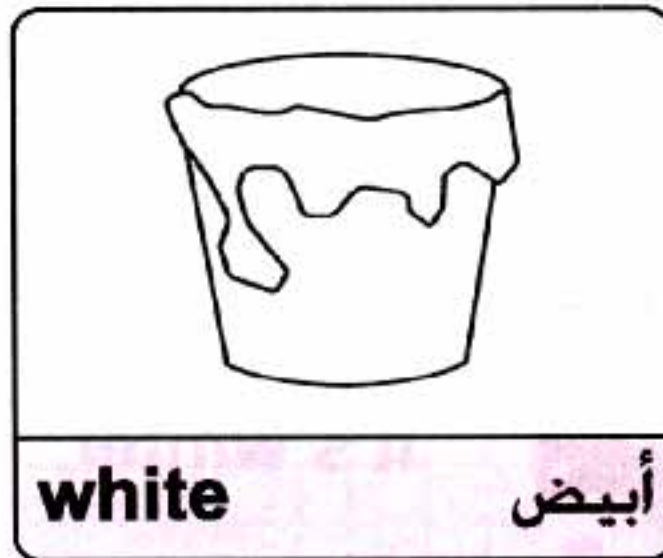

Unit 4

Language Use

1 • What color is it?

- للسؤال عن لون شيء (ما لونها):

What color is it?



It's orange.



What color is it?



It's red.



What color is it?



It's yellow.

It's a duck.
What color is it?

It's brown.



Summer



It's summer.



It's winter.

Activities

1 Match.

صل.

1) red •

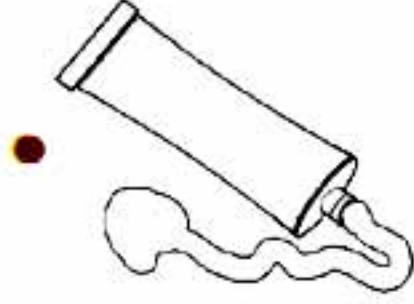

2) yellow •



3) green •



4) gray •

5) brown •

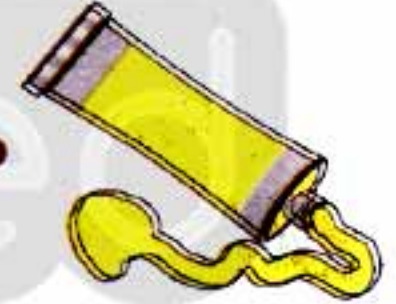

6) white •

2 Trace and color.

تتبع النقط و لون.

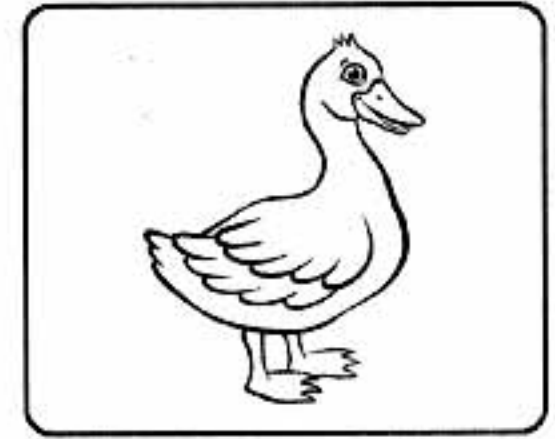
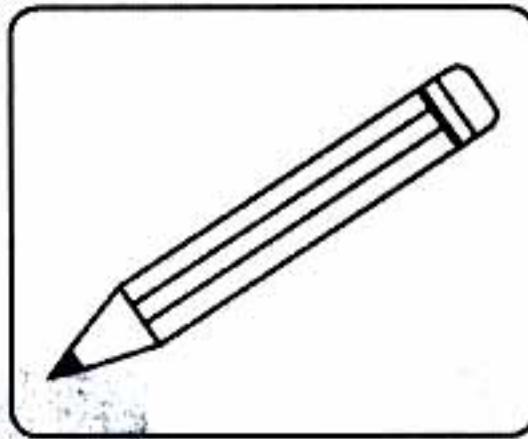
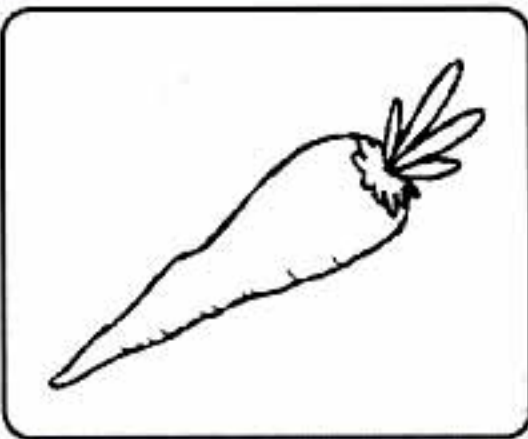

orange

blue

brown

Unit 4

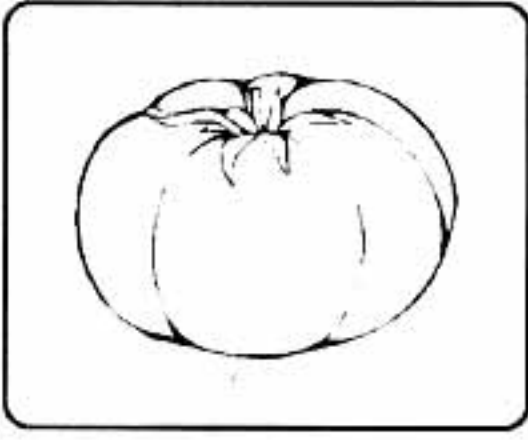

red

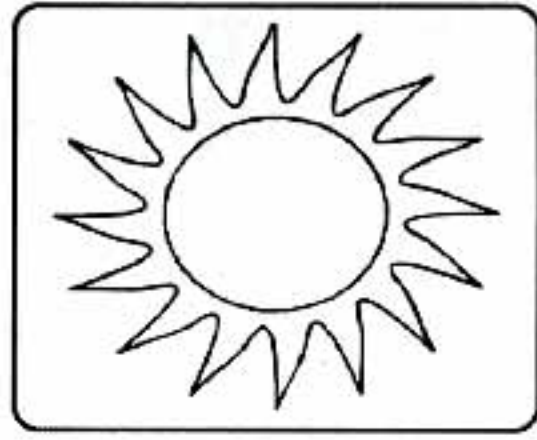

yellow

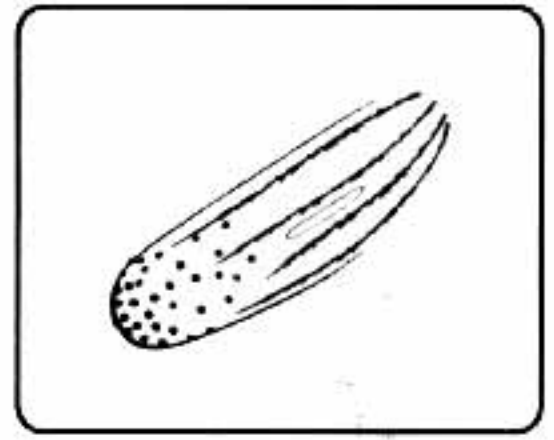

green

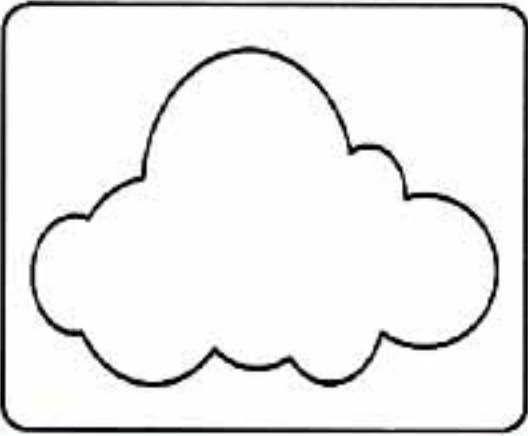

gray

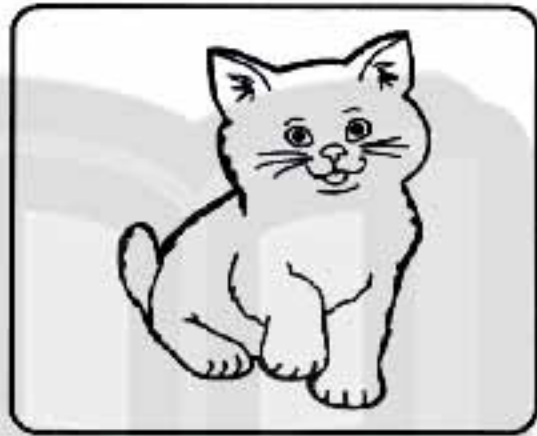

black

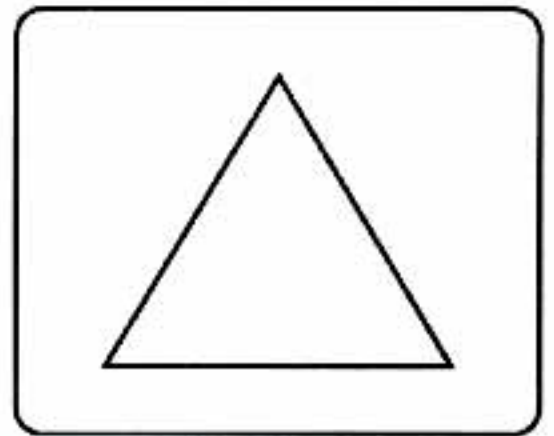

white

3 Look and tick (✓).

أنظرو وضع علامة (✓).

1) It's green.



Yes

No

2) It's white.



3) It's red.



4) It's brown.



5) It's gray.



6) It's yellow.



Writing corner



salad

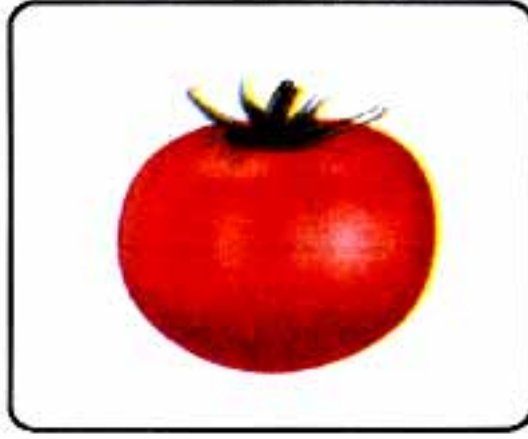

tomato



cucumber

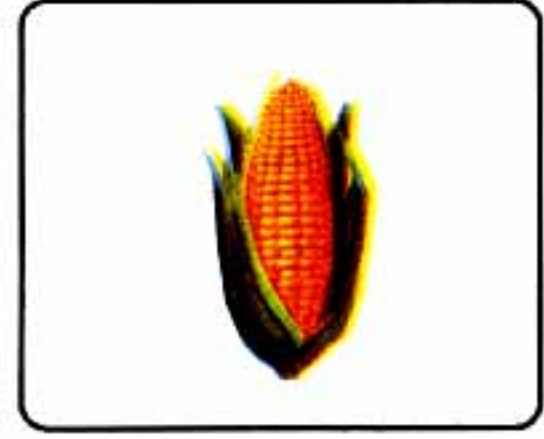

corn



تابع جديد زاكروولي على موقعنا
<https://www.zakrooly.com>

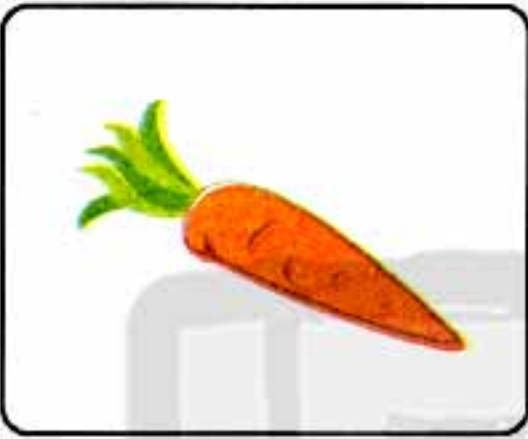

carrot



lettuce



dog

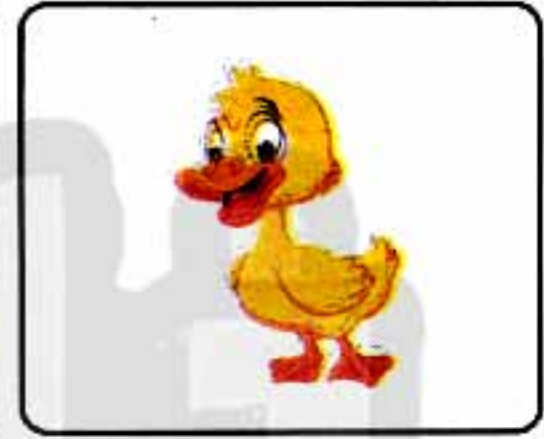

duck



cloud



rain



sea

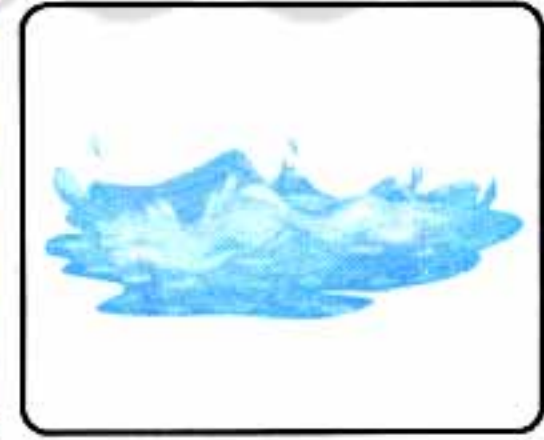

puddle



تابعنا على صفحتنا على الفيسبوك
www.facebook.com/ZakroolySite

Unit 4



hand



daddy



Dina



gray



تابعنا على صفحتنا على الفيسبوك
www.facebook.com/ZakroolySite

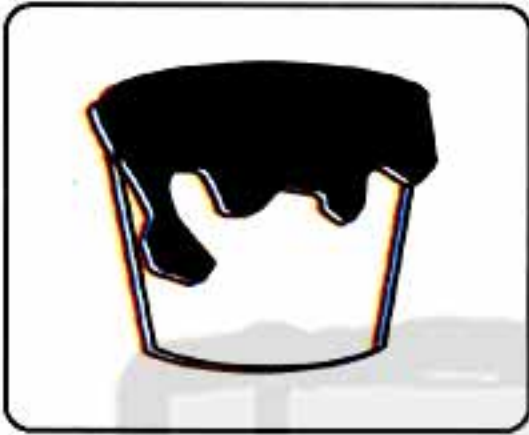

black

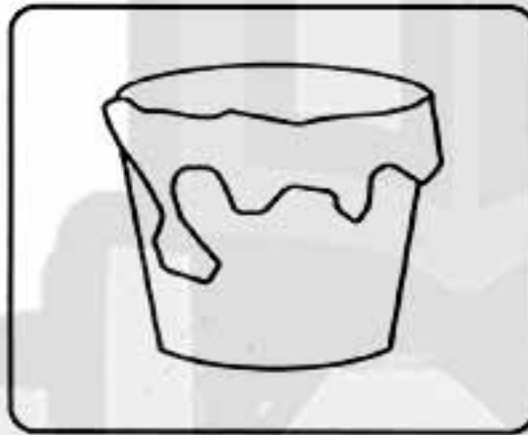

white



red



green



تابع جديد زاكروولي على موقعنا
https://www.zakrooly.com



blue

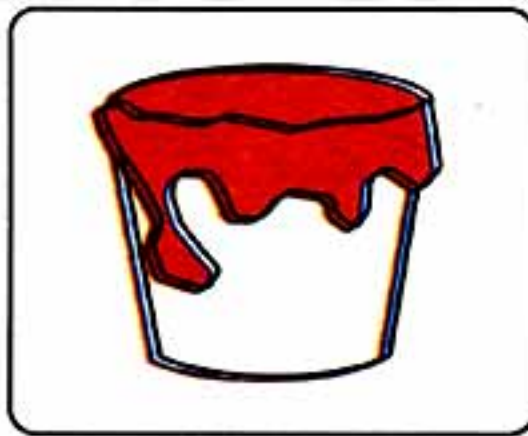

orange

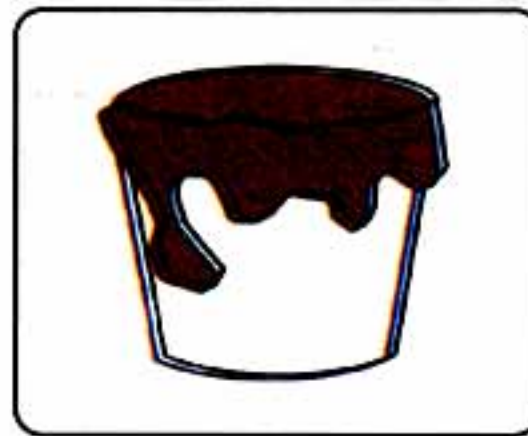

brown

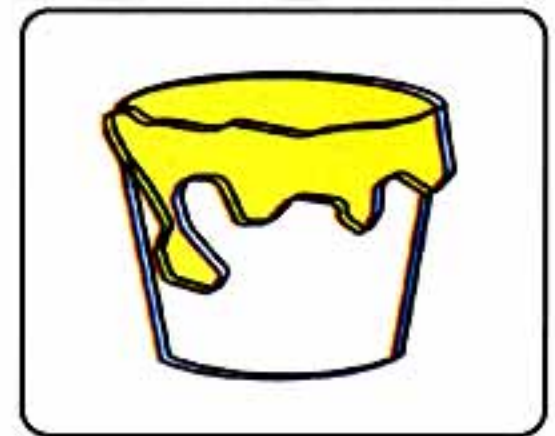

yellow

The Boys and the Frogs



اكتب ذاكرولي في البحث وانضم لجروبات ذاكرولي
مع رياض الاطفال للصف الثالث الاعدادي

Story



This is Seleem. This is Mazen.
هذا سليم - هذا مازن



Let's play! دعنا نلعب



Look! It's a pond!
انظر. إنها (البركه) البحيرة.



I can see water. أنا أستطيع أن أرى الماء.
I can see flowers. أنا أستطيع أن أرى الأزهار.



We are happy frogs.
نحن ضفادع سعداء.



We like our pond.
نحن نحب (بركتنا) بحيرتنا.

Story



This is fun! هذا مرح (متع).



We are sad frogs. نحن ضفادع حزينة.



We like this game! نحن نحب هذه اللعبة.



Stop. توقف.

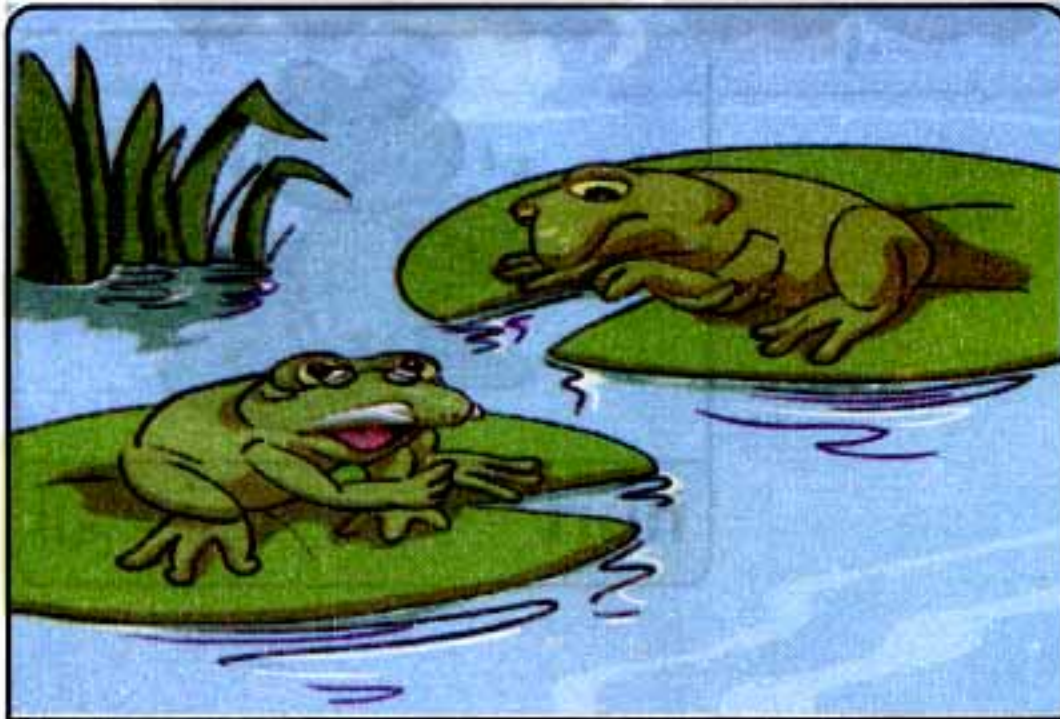

My friend is hurt! صديقي تأذى!



Sorry, frogs! آسف يا ضفادع.

Story



We are **friends**. نحن أصدقاء

Dictionary قاموس

Look and read



play يلعب



pond بركة مياه



happy سعيد



sad حزين

لا تنس الاشتراك في
قنوات ذاكرولي
على تطبيق الأليجرام



hurt ألم - أذى

اكتب ذاكرولي في البحث وانضم لجروبات ذاكرولي
مع رياض الأطفال للصف الثالث الاعدادي

1 Read and circle.

أقرأ و ضع دائرة حول الإجابة الصحيحة.



Seleem and Mazen can see (**frogs** / **flowers**).



The frogs like the (**pond** / **park**).



Seleem and Mazen are (**brothers** / **friends**).



The frog is (**happy** / **sad**).

لا تنس الاشتراك في
قنوات زاكروولي
على تطبيق التليجرام

تابع جديد زاكروولي على
فيسبوك
تويتر
وانس اب
تليجرام